

# FIORE

CUCINE

---

# TECHNICAL MANUAL

---



# WELCOME TO FIORELIFE™

Thank you for choosing a Fiore™ product. This certificate and technical manual is our commitment and guarantee of authenticity and contains a comprehensive overview of Fiore kitchen options and technical information.



## FIORE™ QUALITY IN TECHNOLOGY

Quality is the essence of Fiorelife™ and finding the balance between avant-garde and restraint has been at the forefront of the Fiore ideal. Fiore's selection of the best raw materials available to ensure unquestionable sustainability and reliability over the lifetime of our products.

In the end, quality will be the standard by which we as a brand and company are measured. Fiore has taken great care and responsibility to ensure our products achieve not only the highest aesthetic standards but more importantly the highest level of production, technical, and quality standards.

We understand that collaboration with industry leaders is a vital ingredient to becoming an industry leader ourselves. Fiore is proud to integrate the production technologies and wood working machinery of Homag Group and Homag – Burkle (Germany), SCM (Italy) and Emme Elle (Italy). For Fiore appliances we have chosen to integrate only the best heating technology into our products and utilize the unsurpassed quality of EGO (Germany) and Eurokera (France/ Saint-Gobin & Corning) glass products.

## FIORE™ QUALITY IN DESIGN

Exceptional design is a way of life and our passion. Fiore is dedicated to creating meaningful kitchen solutions that celebrate a progressive lifestyle. Our team of engineers and designers are constantly integrating new technology and processes into our product designs to fortify the balance between aesthetic luxury and uncompromising quality.

Our European modular cabinetry offers versatility in the living environment and brings harmony between the avant-garde and restraint. Fiore's collections stay focused on timeless and sophisticated design yet while seamlessly incorporating contemporary nuances which cater to modern-day lifestyle tendencies.

# TEXTURES . COLORS . WOOD SPECIES

## ! FOR YOUR CONSIDERATION

I. For an accurate evaluation and representation of finishes and colours Fiore highly suggests using physical samples.

II. It is standard and customary for certain materials and finishes to have a natural variance in tone and design characteristics. This is an inevitable result of the manufacturing process and cannot be considered cause for a complaint.

III. All Fiore finished doors and panels may change tone and colour over the course of time due to exposure to natural, ambient, and artificial light. This is a natural effect of the aging process.

## CARCASSES - INTERIORS

### MELAMINE



Bianco



Grigio

## FINISHES - EXTERIORS

### MELAMINE

#### Corso Collection

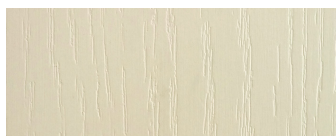

Avorio



Bianco



Bianco Lucido



Bianco Opaco

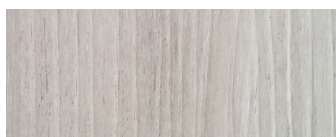

Fiamma Cenere

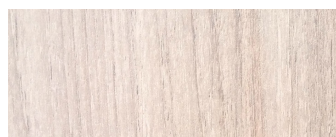

Fiamma Nocciola



Giallo Limone



Nero Pianoforte



Olmo Oro

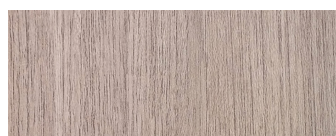

Olmo Platino



Olmo Rame

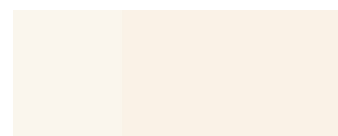

Pergamena Lucido



Rosso Rubino

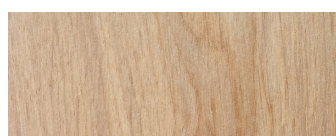

Rovere Nodino Naturale

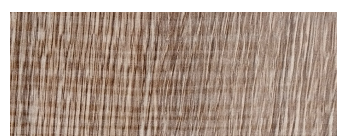

Tranche' Tobacco



Visone Opaco

## Veneto Collection



Bianco Assoluto



Giallo Miele



Grigio Grafite



Larice Nordico



Nero Vulcano



Papiro



Syncro Bianco

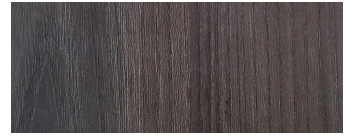

Syncro Grafite

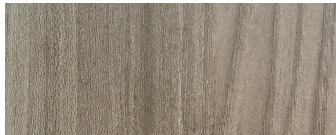

Syncro Noce

## Via Collection

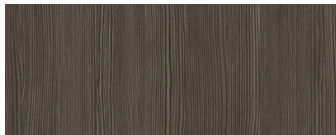

Carbon Ash

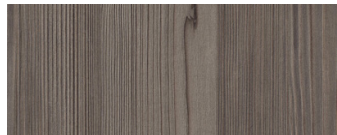

Early Dusk

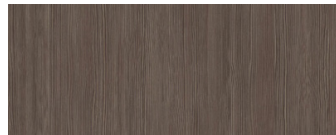

Graphite Ash



Morning Fog

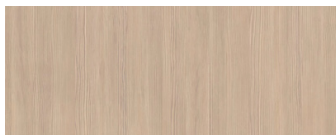

Nude Ash



Oak Ridge

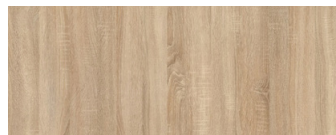

Oak Valley

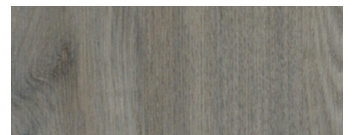

Pewter Bronze



Platinum Oak



Rough Sawn - White



Rustic Light

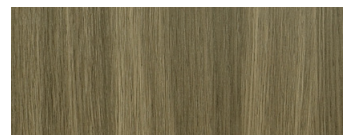

Smoked Oak



Twilight Bronze



Woodside

# POLYESTER LACQUER

---

(Matte / Glossy)



Yuta



Visone



Tortora



Senape

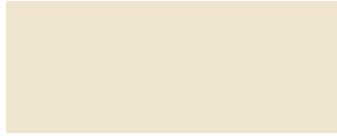

Sabbia



Rosso Fuoco



Nero



Moka

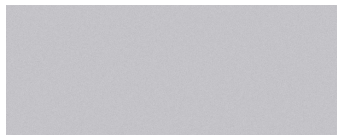

Metall. Acciaio



Magnolia



Grigio Seta



Grigio Pietra



Grigio Grafite



Grigio Ghisa

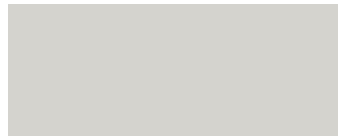

Grigio Cenere



Cobalto

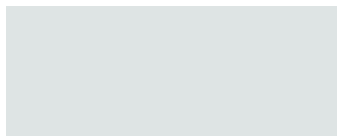

Carta Da Zucchero



Caffelatte



Bordeaux



Bianco Ghiaccio

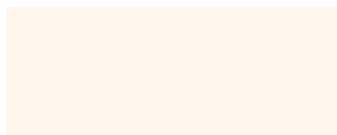

Bianco Burro



Azzurro India



Arancio

# WOOD VENEER

---

## Castagno Collection

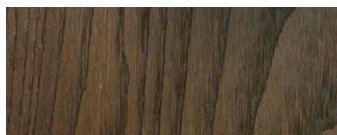

Castagno Moro

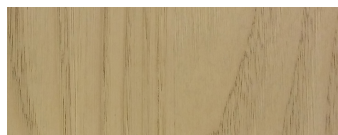

Castagno Naturale

## Rovere Collection



Rovere Bianco

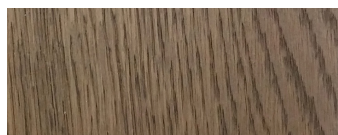

Rovere Cuoio

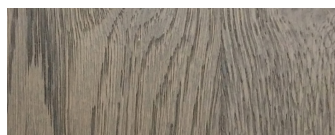

Rovere Dark Grey

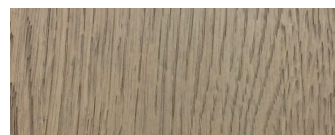

Rovere Light Grey

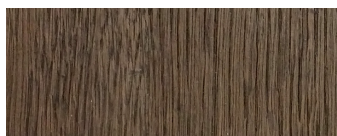

Rovere Moro



Rovere Naturale

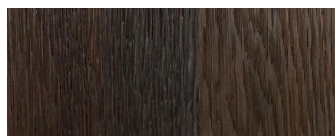

Rovere Termocotto

# WORKTOPS / BACKSPLASHES

QUARTZ BY  CITAL

## Essenza Collection

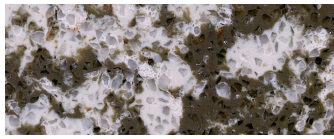

Alaska



Bell

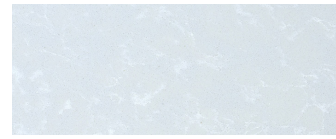

Grey Ocean



New England

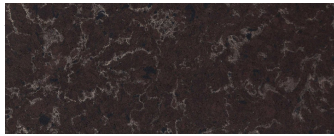

Pietra Gray

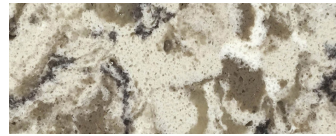

Silver Lining

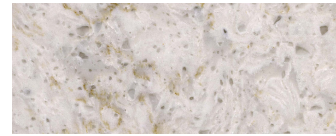

Tequila

## Grana Fine Collection

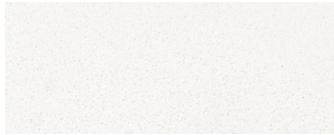

Arctic White

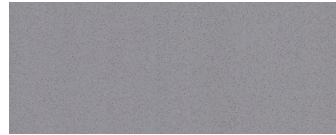

Cement



Dawn



Grey Sand



Gunmetal

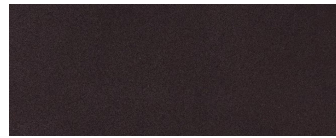

Mattina



Morning Mist



Noir

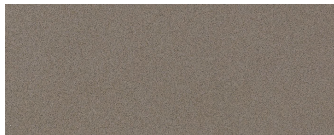

Pelle

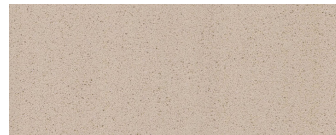

Sabbia

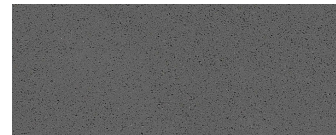

Slate Grey



Super White



Taupe

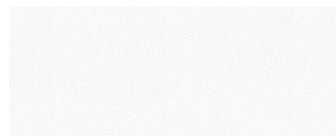

Wales

## Grana Media Collection

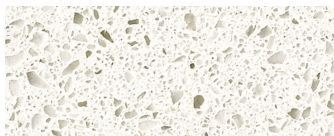

Crystal White



Dusk



Light Pewter

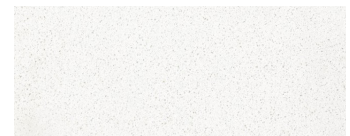

Linen



Luna

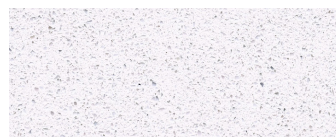

Silver White

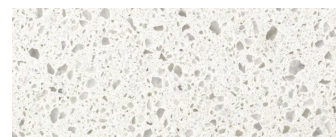

White Pearl

## Nuomar Collection



Aria Bianco

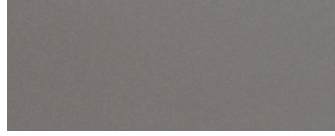

Barka



Bianco Venato

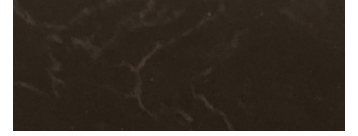

Bronzo



Calm Carrara



Carrara



Carrara Special



Carrara Unique

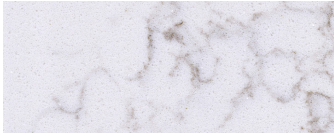

Echo

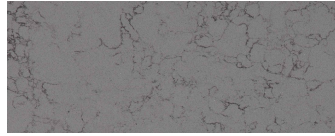

Ice Age



Mezzanotte

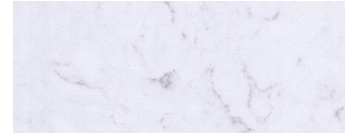

Misty Carrara



New Carrara

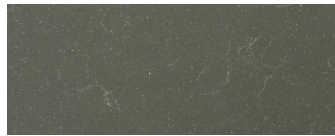

Rain Grey

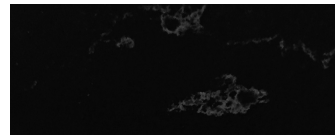

Shadow Ridge

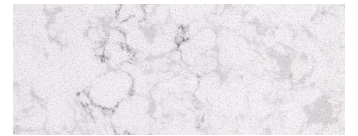

White Rock



NATURAL MARBLE BY  CITAL

---



Bianco Carrara

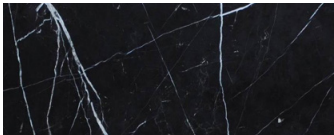

Nero Marquina

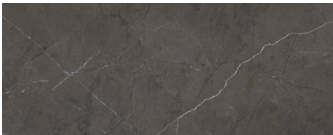

Pietra Gray

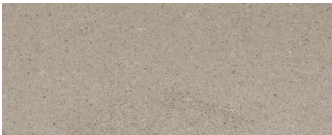

Granitello

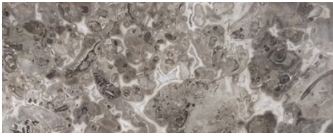

Palermo Gray

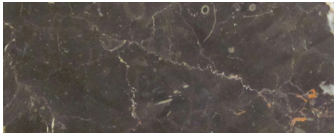

St-Laurent East



Sorrento



---

**FIORILIFE**™

---

## PRICE RANGE FOR EXTERIOR FINISHES

FINISH	TYPE OF MATERIAL	COLOURS / SPECIES	PRICE
MELAMINES	.2mm melamine resin, water repellent/Edge: 1.5mm Abs edging	Various Color Range	
FIORE™ FOILS AND ACRYLICS	Thermofoil (PVC) / .45mm	Various Color Range	
POLYESTER MATTE LACQUER	Polyester resin / .4mm	Various Color Range	
POLYESTER HIGH-GLOSS LACQUER	Polyester resin / .4mm	Various Color Range	
WOOD VENEER	Wood Veneer / .5mm	Various Colors and Species	

# MATERIALS . ACCESSORIES . TECHNICAL

## CARCASSES

### WOOD BASED CARCASS PANELS A/B

All wood based carcass panels offered and used by Fiore™ are 18mm thick and environment-friendly E1 (E1W100) panels (0.015 - 0.1 Concentration (ppm) in 40 m<sup>3</sup> chamber 1 /Perforator value(mg/100g)<sup>2</sup>) with very low formaldehyde emissions and conform to international environmental testing requirements standards.

Wood base panels are treated and finished with high-performance melamine resin; available in White Ice and Bronze Burl finish.

### BASE PANELS FOR SINK BASE CABINETS C

All sink base cabinets are equipped standard with light-commercial grade aluminium base panels to protect from possible water leaks.

### BACK PANELS D

Back panels are made of melamine resin coated MDF (medium density fiberboard) and are 5 mm thick. Back panels are available in White Ice and Bronze Burl finish.

### SHELVES E

Fiore™ shelves are 18 mm thick, treated with high performance melamine resin, and match the interior finish as the carcass (white Ice and Bronze Burl)

### PLINTH F

Plinths are extruded Aluminium profiles with satin stainless steel finish. Plinths are also available in 18mm MDF (medium density fiberboard) in high-gloss and matte lacquer finishes. Plinths are installed at the foot of the unit with special plastic hooks to allow easy removal for cleaning.

### FEET FOR BASE UNITS G/H

Base cabinet feet are available in 80mm, 100mm, 150mm heights and are equipped with telescopic adjustable mechanisms which allow for height adjustment (-5/+20 mm)

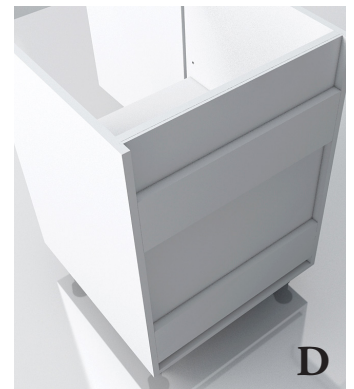
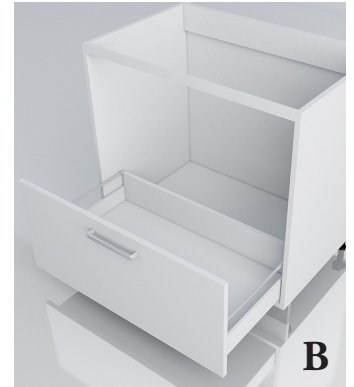

## HINGES

I/J

Fiore™ is proud to integrate the German engineering of Hettich™ hinges in all base cabinets. We offer several models including Sensys™, SlideOn™, Selekt™ and fast assembly models to accommodate the diverse needs of the kitchen environment.

All hinges are equipped with integrated hinge or carcass buffers for soft-closing movement.

## WALL CABINET LIFT SYSTEMS

K/L

Fiore™ is proud to integrate the Austrian engineering of Blum® lift systems in upper/cabinets. We offer several models including Aventos™, and Servo-Drive™ for Aventos™ to accommodate the diverse needs of the kitchen environment.

## MOUNTING BRACKETS FOR WALL CABINETS

M/N

6" concealed wall brackets and hangers, with a maximum load of 65Kg. /unit (equivalent to 260Kg. of final load per set). Adjustable steel guide up to 16 mm and height adjustments up to 18 mm.

## DRAWERS AND HEAVY-DUTY DRAWERS

O/P

Fiore™ offers InnoTech™ from Hettich® double-walled steel drawer systems. Numerous options for individualising and organizing are available including: decorative profiles, railings, Design Sides, Top Sides, interior organisers. Drawers systems are equipped with partial or full-extension runners with a loading capacity up to 70 kg.

## ELECTRO-MOTION OPENING SYSTEMS Q/R

Base cabinets are also available with Blum® Servo-Drive™ electro-motion opening systems.

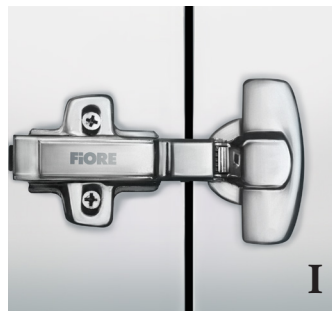

I

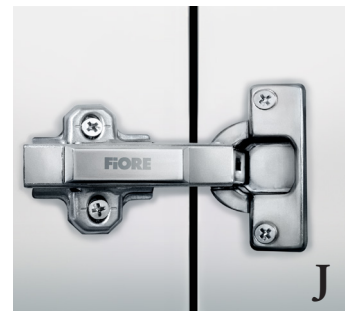

J



K



L



M



N



O

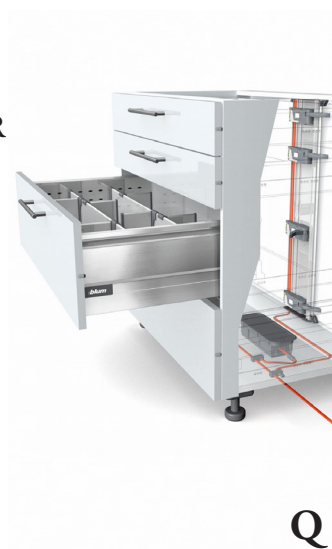

Q



P



R

# DOORS

## TECHNICAL DETAILS

## DESCRIPTION



### MELAMINE

Panel Core: 18mm engineered wood particle board (Class E1 W100 low formaldehyde emission)  
Exterior Material: .2mm melamine resin, water repellent (v100 standard)  
Edge: 3mm Abs edging

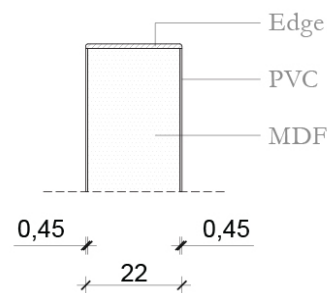

### FIORE FOIL™

Panel Core: 22mm MDF (medium density fiberboard, class E1)  
Exterior Material: .45mm thermofoil

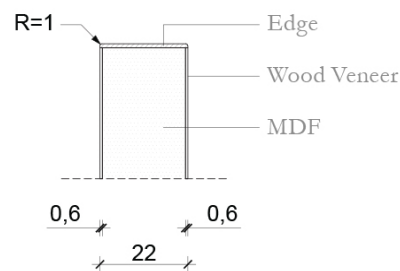
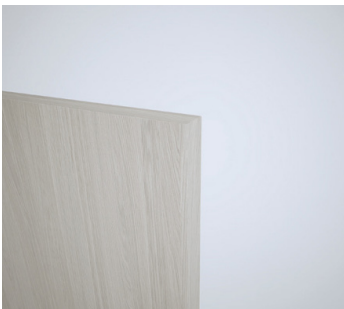

### WOOD VENEER

Panel Core: 22mm MDF (medium density fiberboard, class E1)  
Exterior Material: .6 mm wood veneer (European Oak, European Walnut, and Wenge)  
Exterior Finish: Matte finish with UV - Oil lacquer

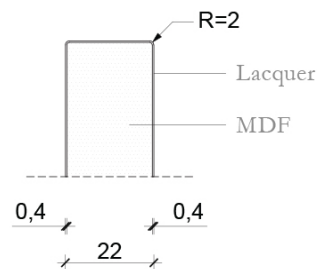
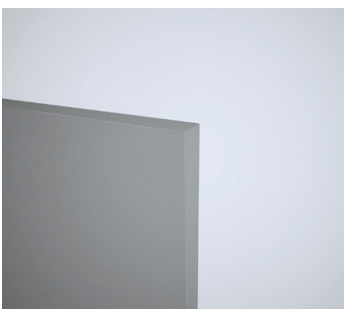

### LACQUER

Panel Core: 22mm MDF (medium density fiberboard, class E1)  
Exterior Material: .4 mm polyester resin  
Exterior Finish: Matte or High-Gloss

# DOOR HANDLES

## COLLECTION AND DIMENSIONS

## SUGGESTED POSITIONING

## MATERIAL

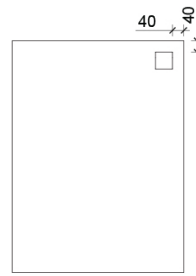
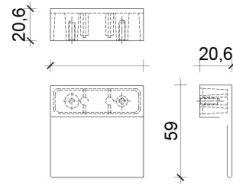

WLS09

Moulded aluminium,  
brushed nickel or  
chrome finish

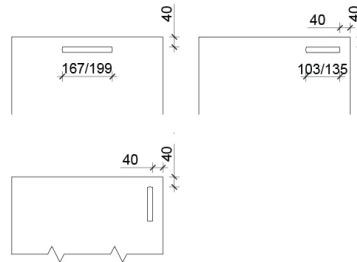
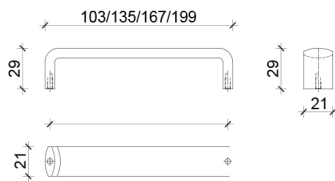

WLS10

Moulded aluminium,  
brushed nickel or  
chrome finish

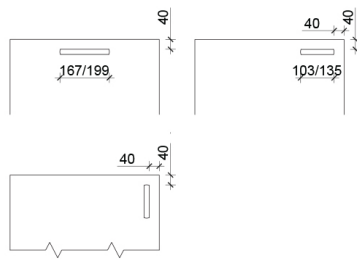
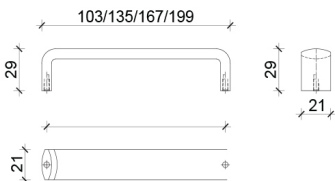

WLS11

Moulded aluminium,  
brushed nickel or  
chrome finish

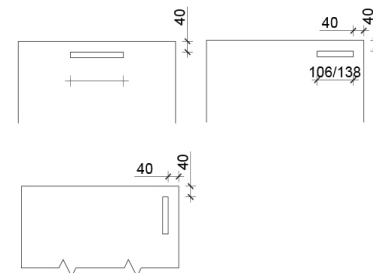
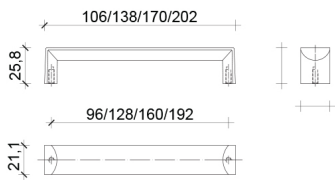

WLS12

Extruded aluminium,  
natural anodised

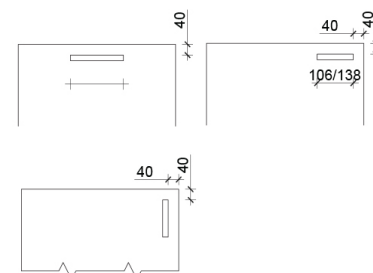
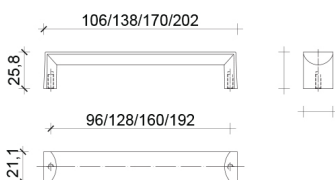

WLS13

Extruded aluminium,  
natural anodised

COLLECTION  
AND DIMENSIONS

SUGGESTED  
POSITIONING

MATERIAL

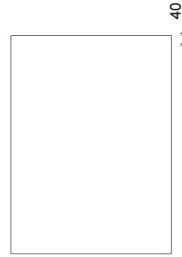
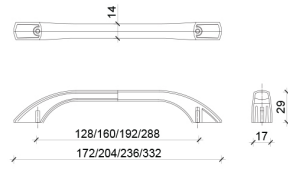

WLS15

Moulded aluminium,  
brushed nickel or  
chrome finish

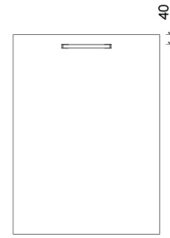
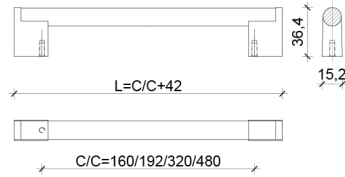

WLS16

Extruded aluminium,  
natural anodised

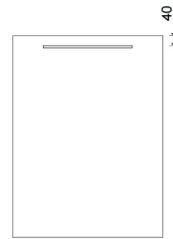

WLS19

Extruded aluminium,  
natural anodised

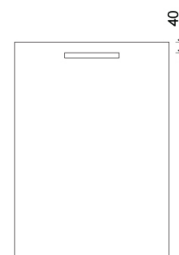
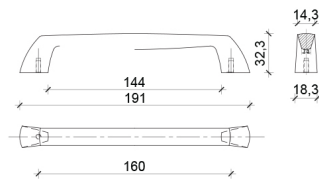

WLS23

Moulded aluminium,  
brushed nickel or  
chrome finish

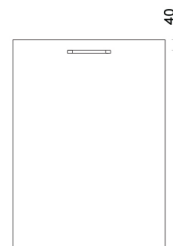
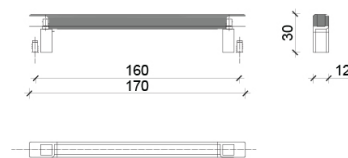

WLS24

Extruded aluminium,  
natural anodised



COLLECTION  
AND DIMENSIONS

SUGGESTED  
POSITIONING

MATERIAL

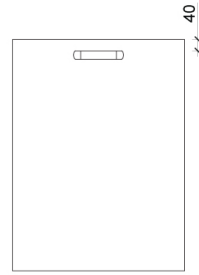
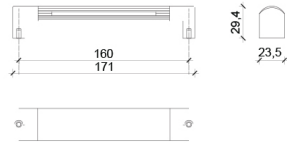

WLS25

Moulded aluminium,  
brushed nickel with  
chrome finish

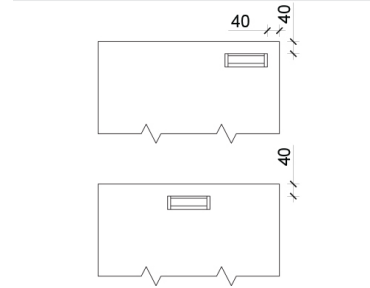
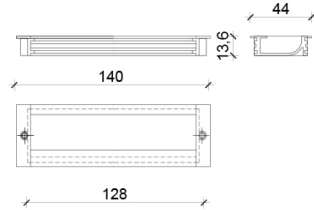

WLS26

Extruded aluminium,  
natural anodised or  
chrome finish

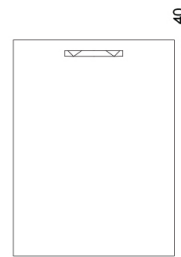
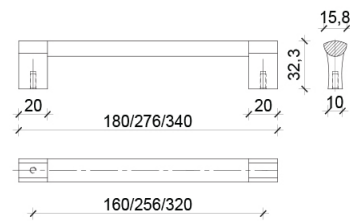

WLS32

Extruded aluminium,  
natural anodised or  
chrome finish

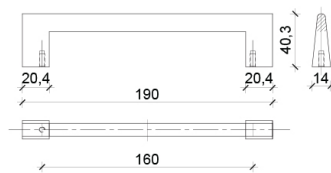

WLS33

Moulded aluminium,  
brushed nickel or  
chrome finish

# INTEGRATED DOOR HANDLES

## COLLECTION AND DIMENSIONS

## MATERIAL

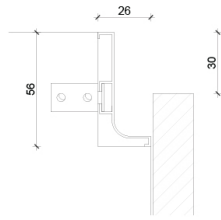

### WKS01A - Base Cabinets

Extruded aluminium,  
natural anodised or black  
anodized

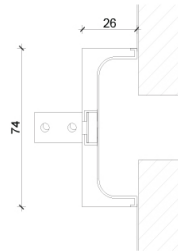

### WKS01E - Base cabinets

Extruded aluminium,  
natural anodised or black  
anodized

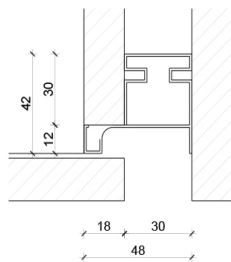

### WKS01C - Tall cabinets

Extruded aluminium,  
natural anodised or  
black anodized

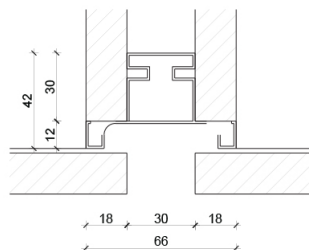

### WKS01D - Tall Cabinets

Extruded aluminium,  
natural anodised or  
black anodized

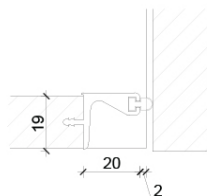
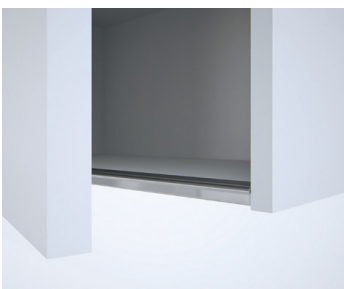

### WKS01/04B - Wall Cabinet

Moulded Zinc Alloy,  
brushed nickel or  
chrome finish

COLLECTION  
AND DIMENSIONS

---

MATERIAL

---

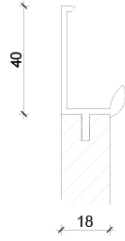

WKS02 - Base Cabinet

---

Moulded Zinc Alloy,  
brushed nickel or chrome  
finish

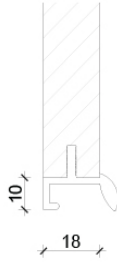

SWKS02/05B -Wall Cabinet

---

Moulded Zinc Alloy,  
brushed nickel or chrome  
finish

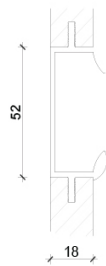

WKS02/05C - Base Cabinet

---

Moulded Zinc Alloy,  
brushed nickel or  
chrome finish



---

**FIORILIFE™**

---

# WORKTOPS

---

QUARTZ BY  CITAL

---



12mm



20mm



30mm

---

# ELA COLLECTION

---



# CARCASS SIZES

## ELA BASE UNITS

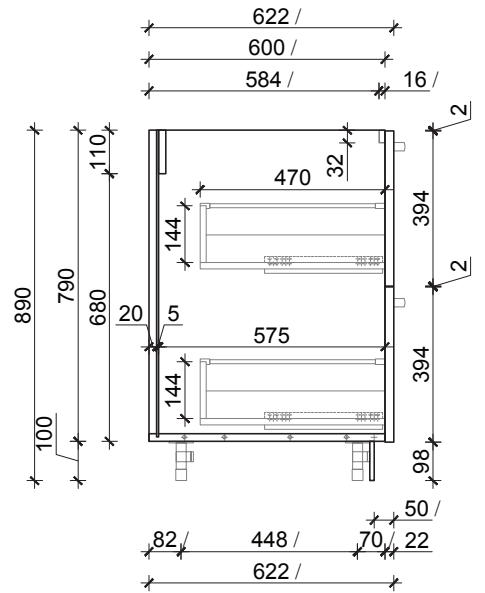
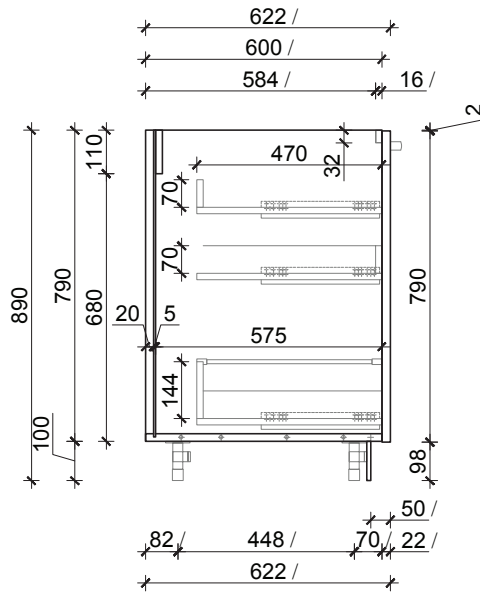
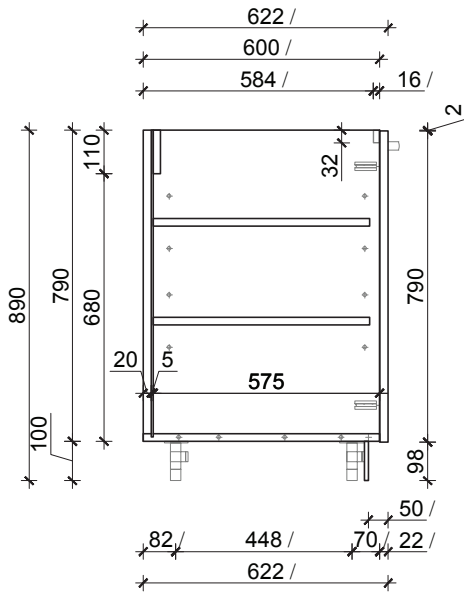
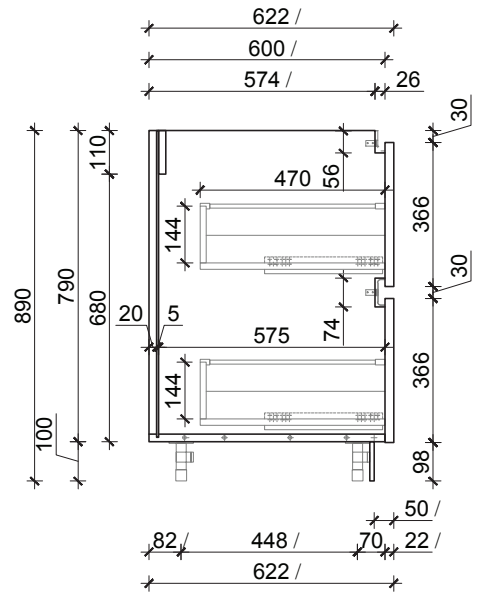
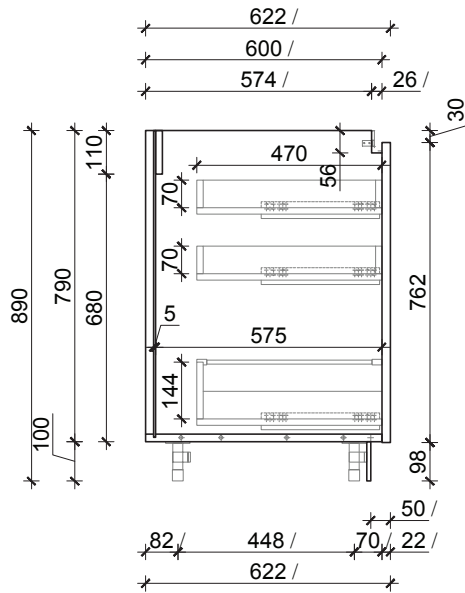
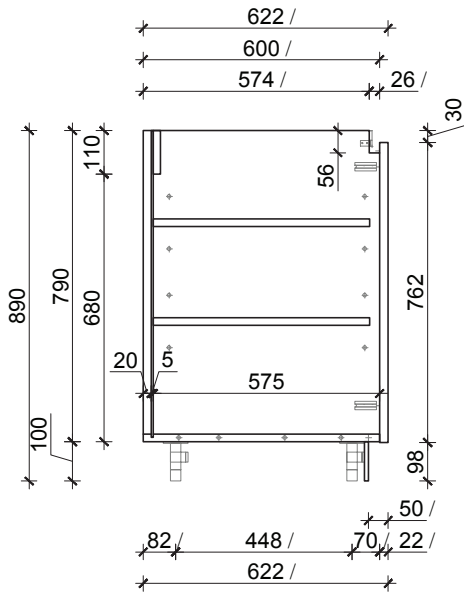

# CARCASS SIZES

## ELA TALL AND WALL UNITS

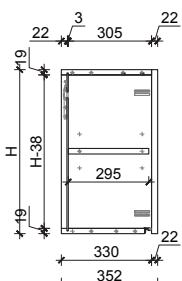
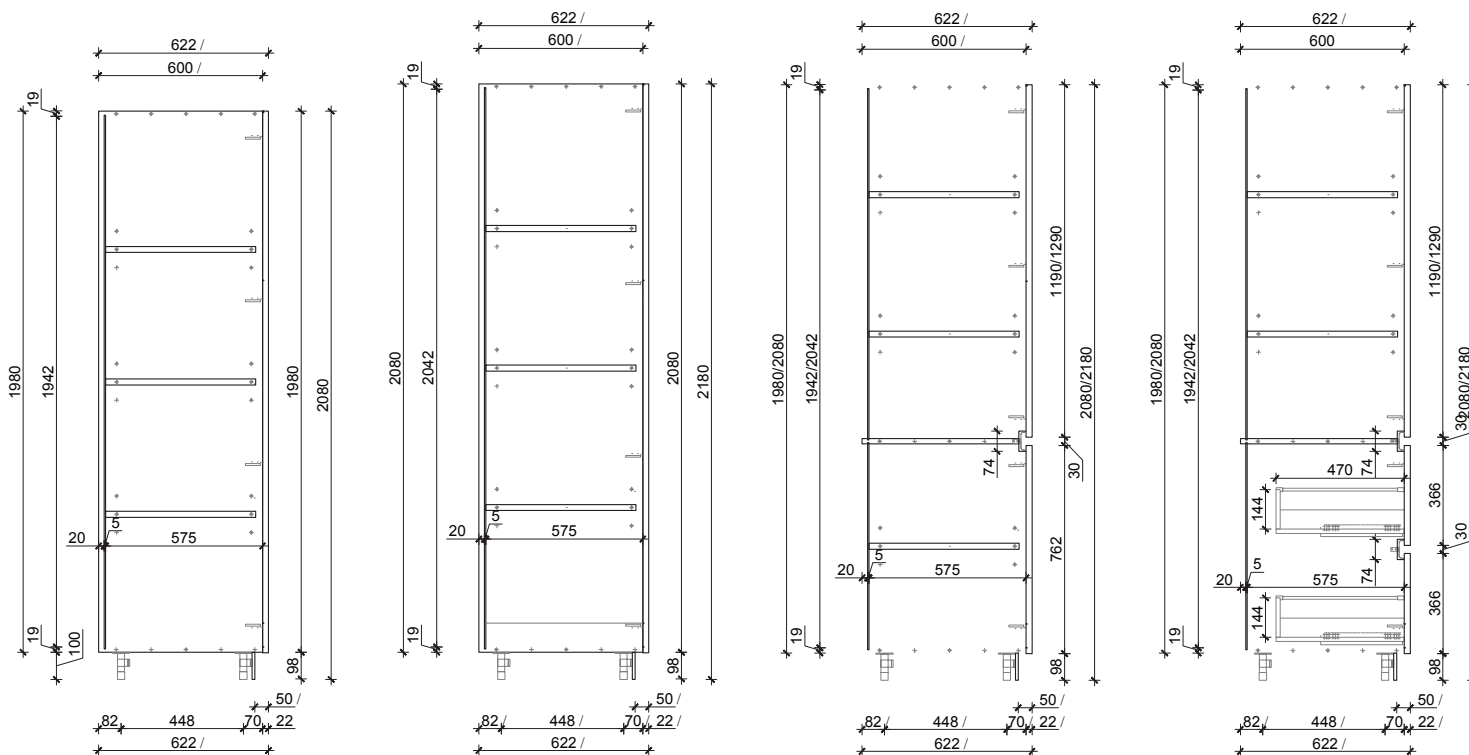

H. cm 36	- no. shelf	0	- 2 hinges
H. cm 48	- no. shelf	1	- 2 hinges
H. cm 60	- no. shelf	1	- 2 hinges
H. cm 72	- no. shelf	1,2	- 2 hinges



# CARCASS SIZES

## ELA TALL AND WALL UNITS

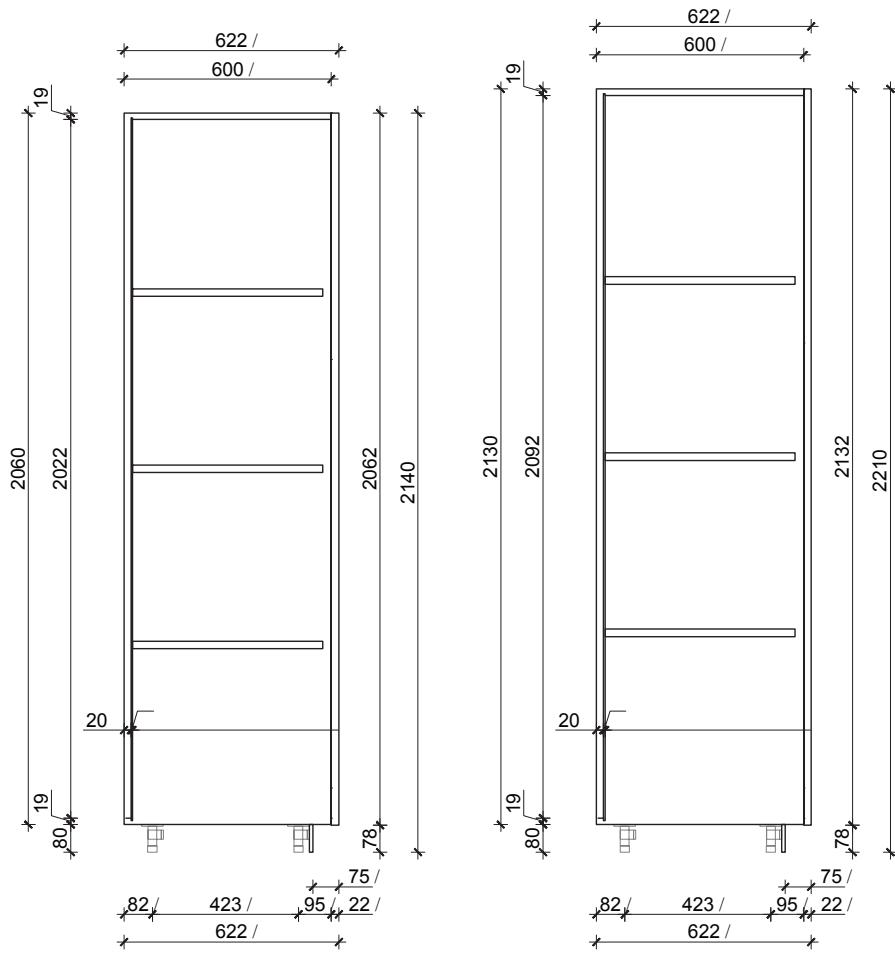

# CARCASS SIZES

## ELA TALL AND WALL UNITS

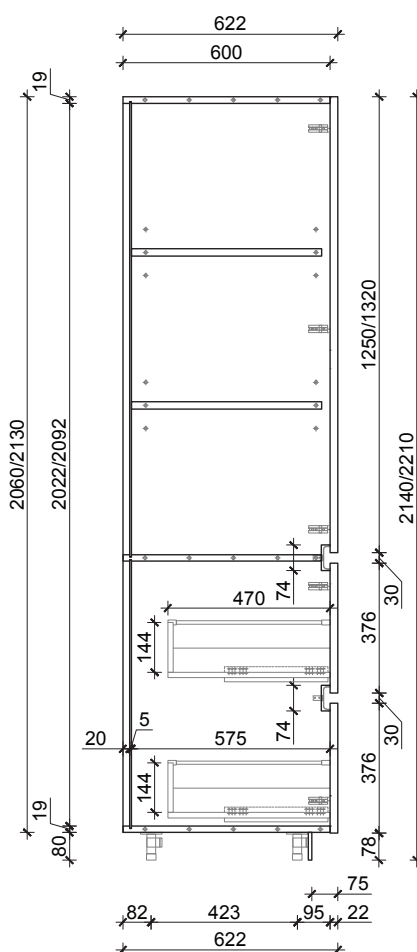
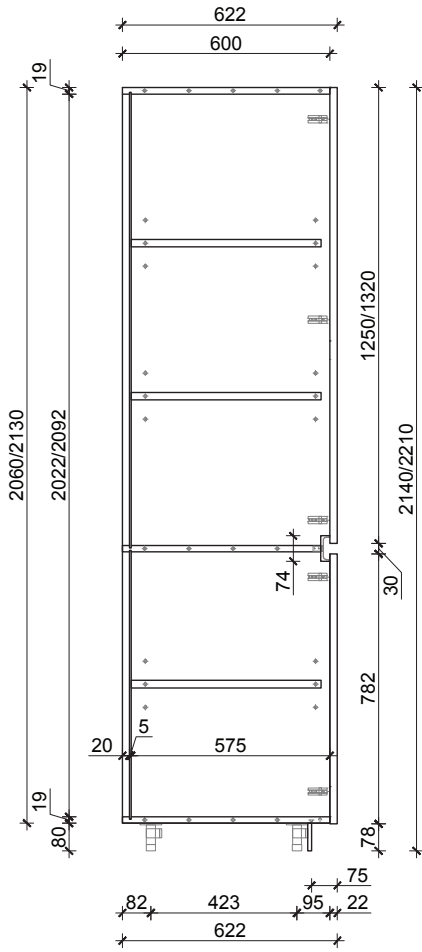

# DESIGN PROPOSALS

## ELA ISLAND

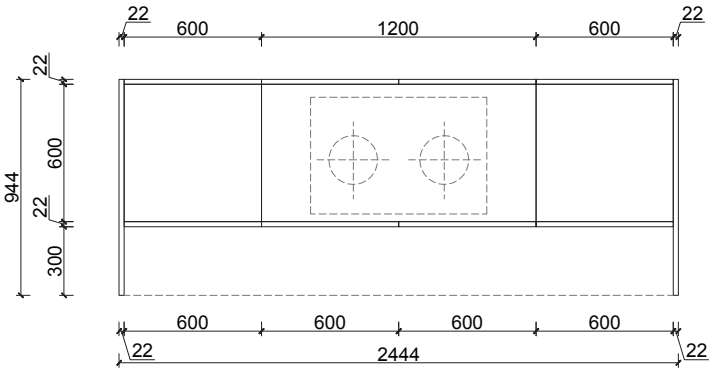
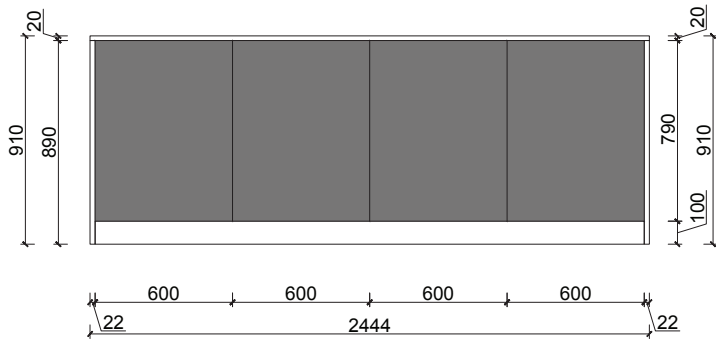
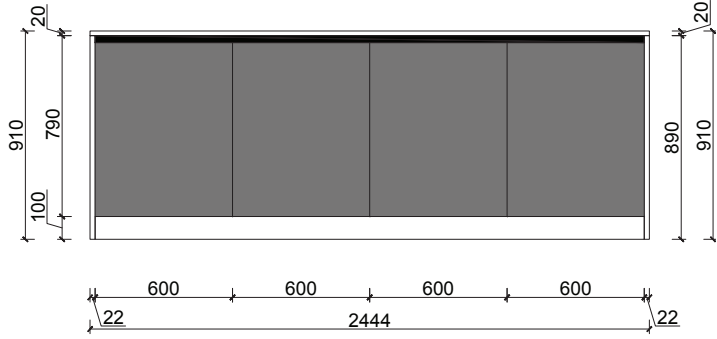

### PROPOSAL 1

1. End side corner panel  
H= 780 mm, W= 88 mm, 944 mm deep, 22 mm thick
2. Quartz stone counter  
20 mm thick, W= 2576 mm
3. Aluminum stainless steel spacer  
W= 2496/864 mm
4. Base unit with shelf  
H= 810 mm, W= 600 mm
5. Base unit with shelf, cook top above  
H= 810 mm, W= 1200 mm
6. Base unit with internal drawers  
H= 810 mm, W= 600 mm
7. Aluminum toe kick  
80 mm high, W= 2486/854 mm
- 8-11. Base unit with shelves  
H= 810 mm, W= 600 mm, 22 mm thick.

# DESIGN PROPOSALS

## ELA ISLAND

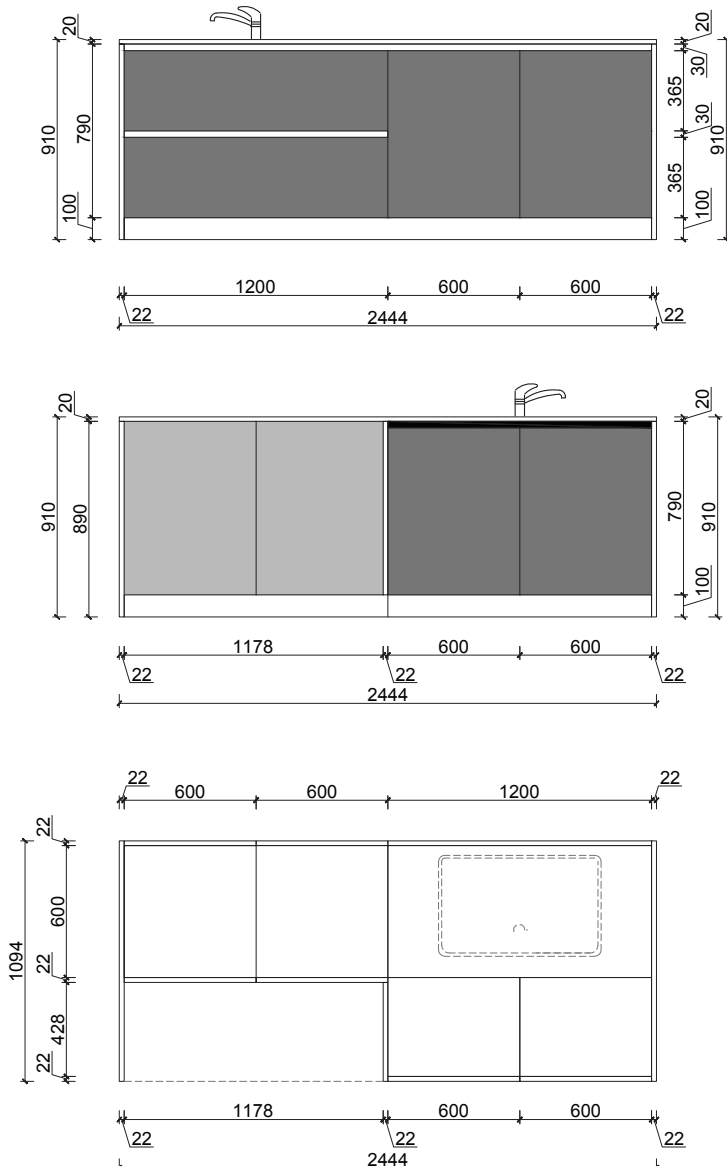

### PROPOSAL 2

1. End side panel  
H= 890 mm, 1094 mm deep, 22 mm thick
2. Quartz stone counter  
20 mm thick, W= 2444 mm
3. Aluminum stainless steel spacer  
W= 2400/1200 mm
4. Aluminum stainless steel spacer  
W= 1200 mm, central use
5. Base unit for sink with drawers  
H= 790 mm, W= 1200 mm
6. Base unit for built-in dish washer  
H= 790 mm, W= 600 mm
7. Base unit with shelf  
H= 790 mm, W= 600 mm
8. Aluminum toe kick  
100 mm high, W= 2400/1200/450 mm
9. Base unit with shelves  
H= 790 mm, W= 600 mm
10. Base unit with shelves  
H= 790 mm, W= 600 mm
11. End back panel  
H= 790 mm, W= 600 mm, 22 mm thick
12. End side panel  
H= 790 mm, W= 450 mm, 22 mm thick.

# DESIGN PROPOSALS

## ELA ISLAND

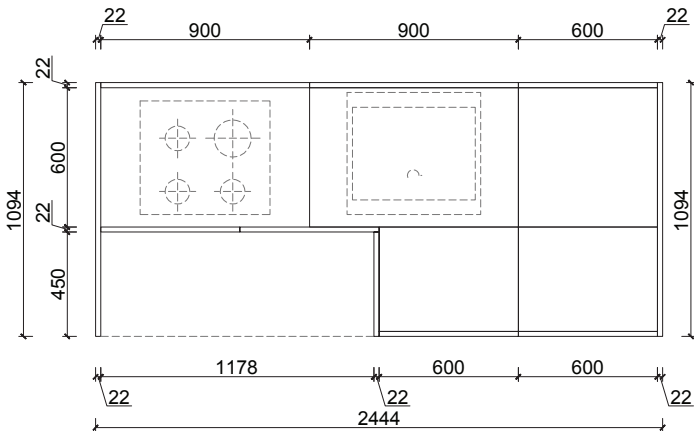
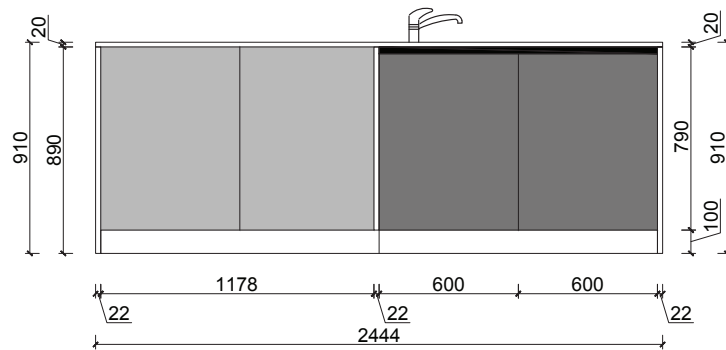
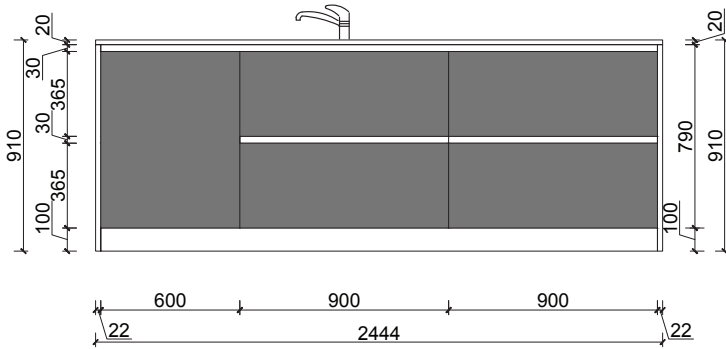

### PROPOSAL 3

1. End side panel  
H= 890 mm, 1094 mm deep, 22 mm thick
2. Quartz stone counter  
20 mm thick, W= 2444 mm
3. Aluminum stainless steel spacer  
W= 2400/1200 mm
4. Aluminum stainless steel spacer  
W= 1800 mm, central use
5. Base unit for built-in dish washer  
H= 790 mm, W= 600 mm
6. Base unit for sink with drawers  
H= 790 mm, W= 900 mm
7. Base unit with drawers, cook top above  
H= 790 mm, W= 900 mm
8. Aluminum toe kick  
100 mm high, W= 2400/1200/450 mm
9. Base unit with shelves  
H= 790 mm, W= 600 mm
10. Base unit with shelves  
H= 790 mm, W= 600 mm
11. End back panel  
H= 790 mm, W= 600 mm, 22 mm thick
12. End side panel  
H= 790 mm, W= 450 mm, 22 mm thick.

# DESIGN PROPOSALS

## ELA ISLAND

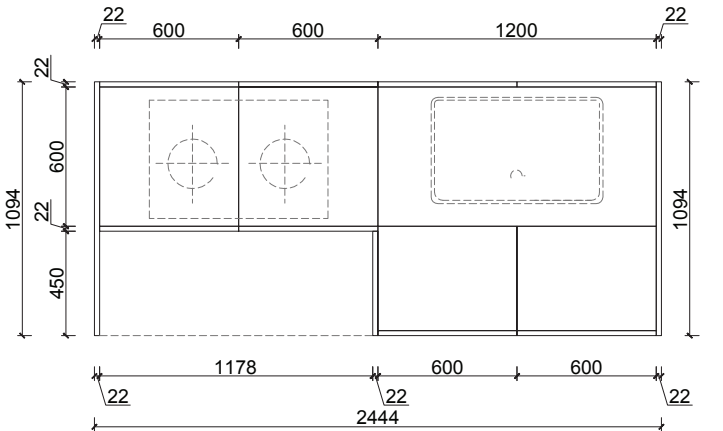
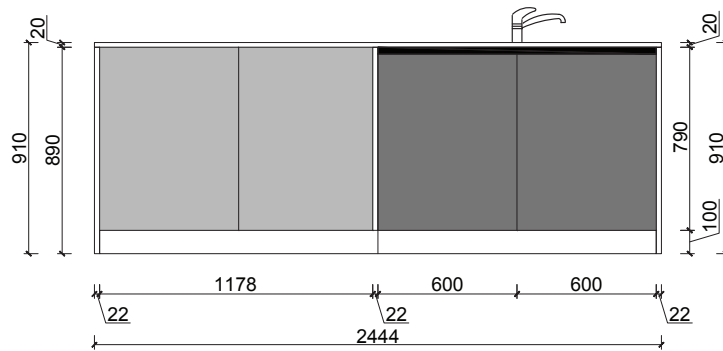
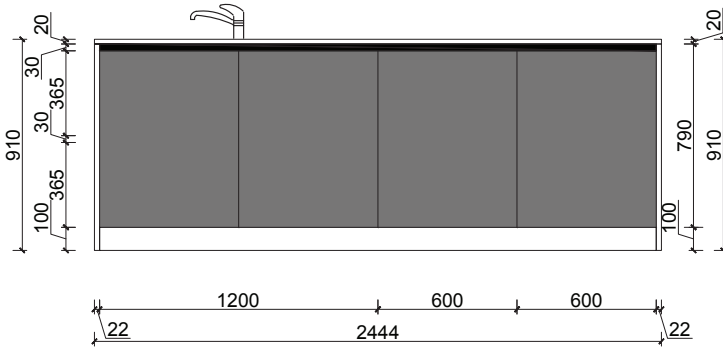

### PROPOSAL 4

1. End side panel  
H= 890 mm, 1094 mm deep, 22 mm thick
2. Quartz stone counter  
20 mm thick, W= 2444 mm
3. Aluminum stainless steel spacer  
W= 2400/1200 mm
4. Aluminum stainless steel spacer  
W= 1200 mm, central use
5. Base unit for sink  
H= 790 mm, W= 1200 mm
6. Base unit for built-in dish washer, cook top above  
H= 790 mm, W= 600 mm
7. Base unit with internal drawers, cook top above  
H= 790 mm, W= 600 mm
8. Aluminum toe kick  
100 mm high, W= 2400/1200/450 mm
9. Base unit with shelves  
H= 790 mm, W= 600 mm
10. Base unit with shelves  
H= 790 mm, W= 600 mm
11. End back panel  
H= 790 mm, W= 600 mm, 22 mm thick
12. End side panel  
H= 790 mm, W= 450 mm, 22 mm thick.

# DESIGN PROPOSALS

## ELA ISLAND

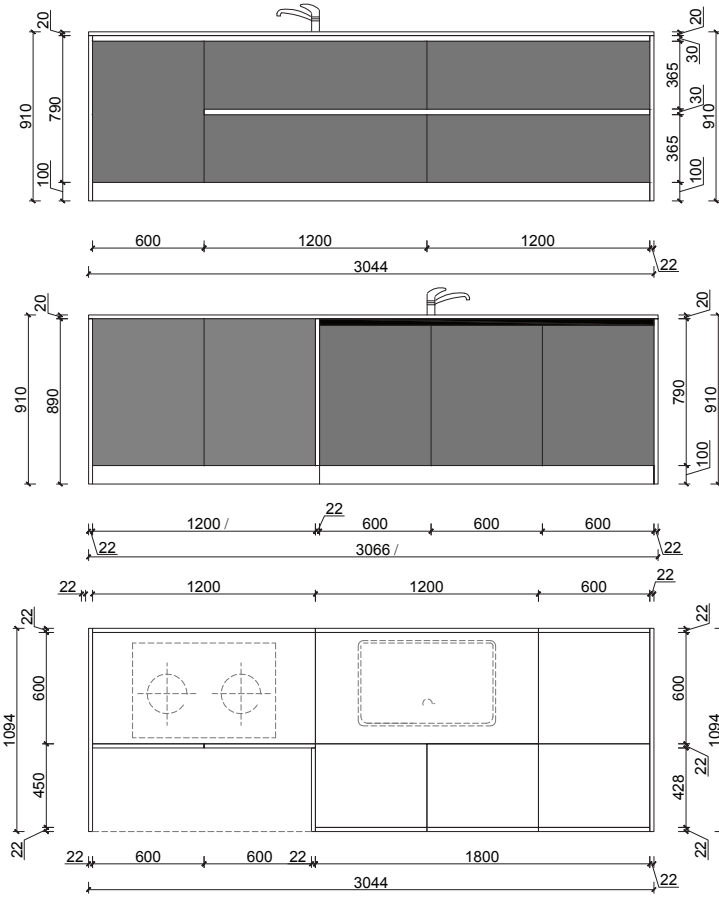

### PROPOSAL 2

1. End side panel  
H= 890 mm, 1094 mm deep, 22 mm thick
2. Quartz stone counter  
20 mm thick, W= 2444 mm
3. Aluminum stainless steel spacer  
W= 2400/1200 mm
4. Aluminum stainless steel spacer  
W= 1200 mm, central use
5. Base unit for sink with drawers  
H= 790 mm, W= 1200 mm
6. Base unit for built-in dish washer  
H= 790 mm, W= 600 mm
7. Base unit with shelf  
H= 790 mm, W= 600 mm
8. Aluminum toe kick  
100 mm high, W= 2400/1200/450 mm
9. Base unit with shelves  
H= 790 mm, W= 600 mm
10. Base unit with shelves  
H= 790 mm, W= 600 mm
11. End back panel  
H= 790 mm, W= 600 mm, 22 mm thick
12. End side panel  
H= 790 mm, W= 450 mm, 22 mm thick.

# DESIGN PROPOSALS

## ELA ISLAND

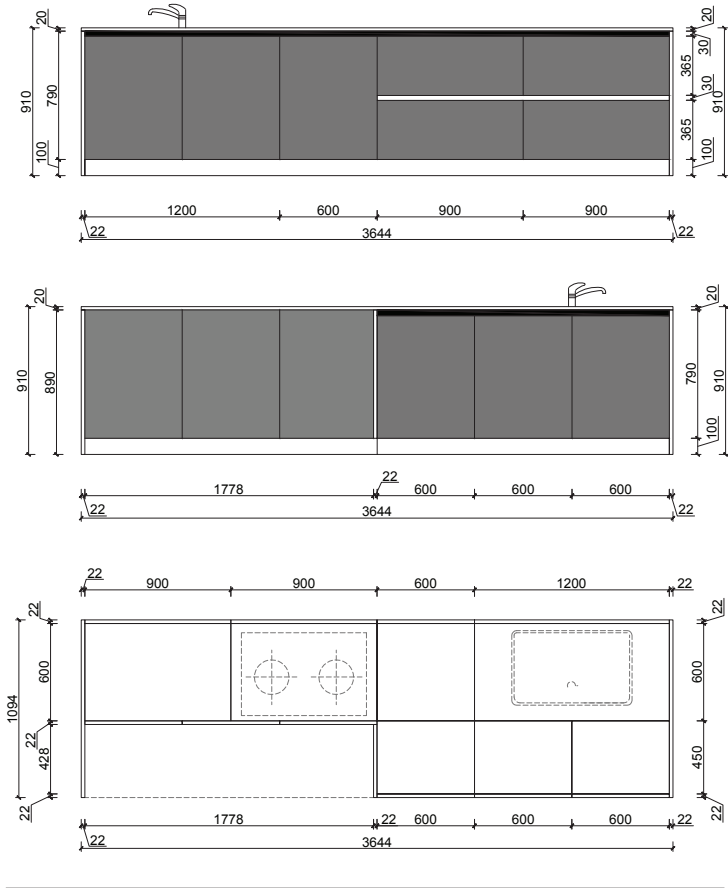

### PROPOSAL 3

1. End side panel  
H= 890 mm, 1094 mm deep, 22 mm thick
2. Quartz stone counter  
20 mm thick, W= 3644 mm
3. Aluminum stainless steel spacer  
W= 3600/1800 mm
4. Aluminum stainless steel spacer  
W= 1800 mm, central use
5. Base unit for sink  
H= 790 mm, W= 1200 mm
6. Base unit for built-in dish washer  
H= 790 mm, W= 600 mm
7. Base unit with drawers, cook top above  
H= 790 mm, W= 900 mm
8. Base unit with drawers  
H= 790 mm, W= 900 mm
9. Aluminum toe kick  
100 mm high, W= 3600/1800/450 mm
10. Base unit with shelves  
H= 790 mm, W= 1200 mm
11. Base unit with shelves  
H= 790 mm, W= 600 mm
12. End back panel  
H= 790 mm, W= 600 mm, 22 mm thick
13. End side panel  
H= 790 mm, W= 450 mm, 22 mm thick



# DESIGN PROPOSALS

## ELA TALL CABINETS

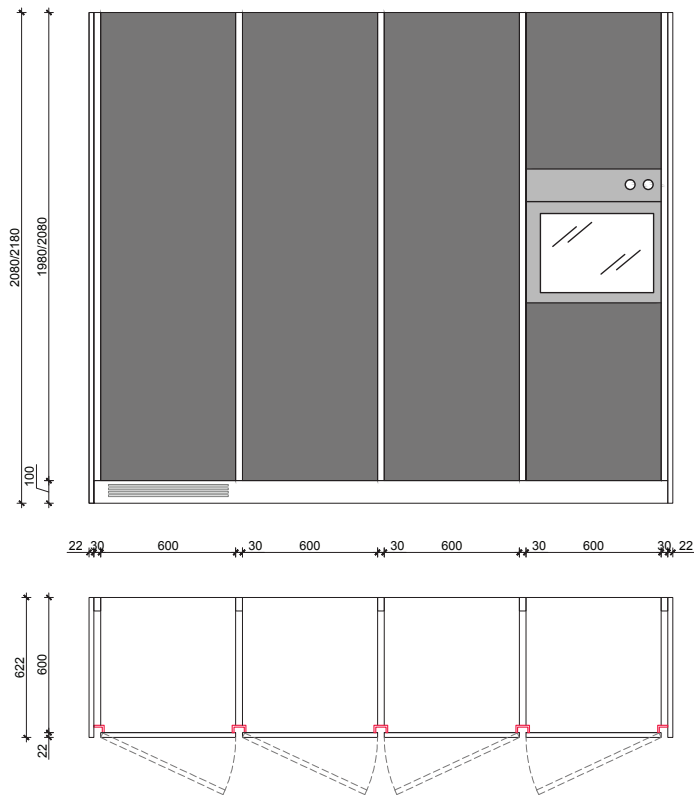

### PROPOSAL 1

1. End side panel  
H= 2080/2180 mm, 622 mm deep, 22 mm thick
2. Aluminum stainless steel spacer  
H= 1980/2080 mm
3. Tall unit for refrigerator  
H= 1980/2080 mm, W= 600 mm
4. Aluminum stainless steel spacer, central use  
H= 1980/2080 mm
5. Tall unit - tandem pantry  
H= 1980/2080 mm, W= 600 mm
6. Tall unit - tandem pantry  
H= 1980/2080 mm, W= 600 mm
7. Tall unit for oven with shelves  
H= 1980/2080 mm, W= 600 mm
8. Aluminum toe kick  
100 mm high, W= 2550 mm.

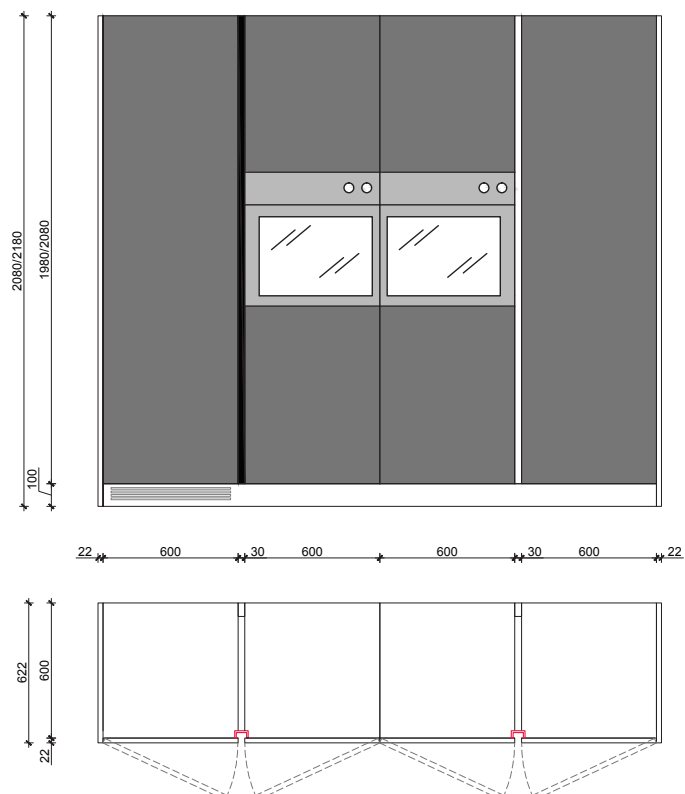

### PROPOSAL 2

1. End side panel  
H= 2080/2180 mm, 622 mm deep, 22 mm thick
2. Tall unit for refrigerator  
H= 1980/2080 mm, W= 600 mm
3. Aluminum stainless steel spacer, central use  
H= 1980/2080 mm
4. Tall unit for oven with shelves  
H= 1980/2080 mm, W= 600 mm
5. Tall unit for oven with shelves  
H= 1980/2080 mm, W= 600 mm
6. Tall unit - tandem pantry  
H= 1980/2080 mm, W= 600 mm
7. Aluminum toe kick  
100 mm high, W= 2460 mm.

# DESIGN PROPOSALS

## ELA TALL CABINETS

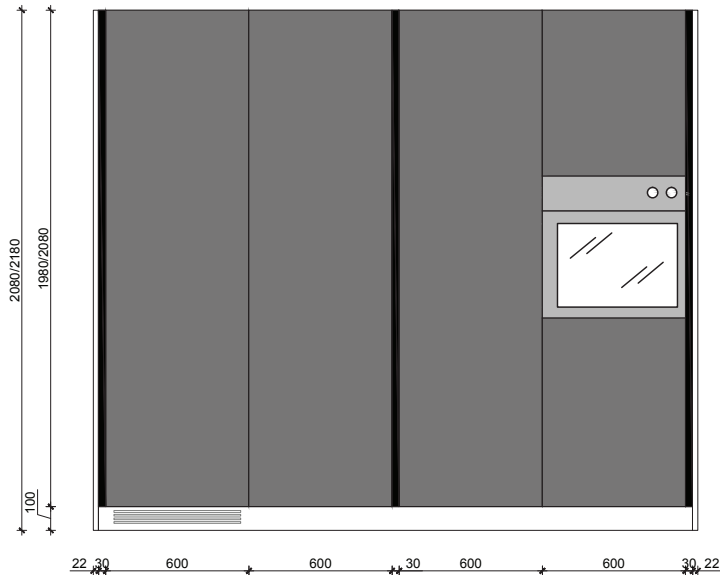

### PROPOSAL 3

1. End side panel  
H= 2080/2180 mm, 622 mm deep, 22 mm thick
2. Aluminum stainless steel spacer  
H= 1980/2080 mm
3. Tall unit for refrigerator  
H= 1980/2080 mm, W= 600 mm
4. Tall unit - tandem pantry  
H= 1980/2080 mm, W= 600 mm
5. Aluminum stainless steel spacer, central use  
H= 1980/2080 mm
6. Tall unit - tandem pantry  
H= 1980/2080 mm, W= 600 mm
7. Tall unit for oven with shelves  
H= 1980/2080 mm, W= 600 mm
8. Aluminum toe kick  
100 mm high, W= 2490 mm.

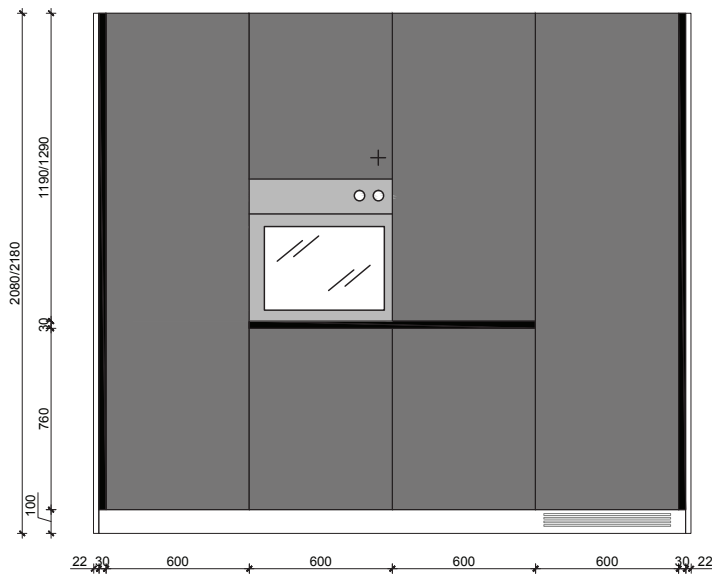
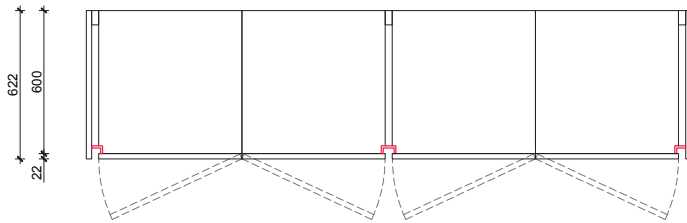

### PROPOSAL 4

1. End side panel  
H= 2080/2180 mm, 622 mm deep, 22 mm thick
2. Aluminum stainless steel spacer  
H= 1980/2080 mm
3. Tall unit - tandem pantry  
H= 1980/2080 mm, W= 600 mm
4. Tall unit for oven with shelves  
H= 1980/2080 mm, W= 600 mm
5. Tall unit with shelves and internal drawers  
H= 1980/2080 mm, W= 600 mm
6. Tall unit for refrigerator  
H= 1980/2080 mm, W= 600 mm
7. Aluminum stainless steel spacer  
W= 600 mm
8. Aluminum stainless steel spacer, central use  
W= 600 mm
9. Aluminum toe kick  
100 mm high, W= 2460 mm.

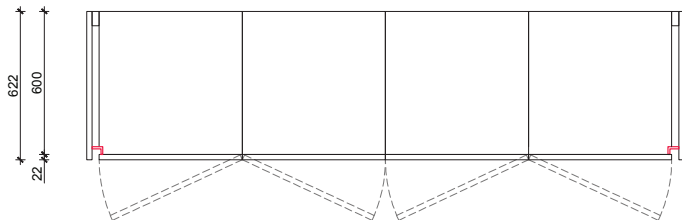

# PROGRAMA STANDARD

## ELA BASE CABINETS

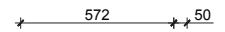
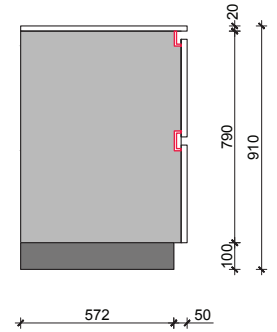
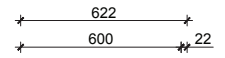
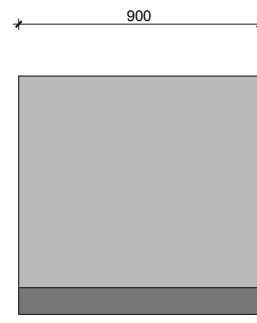
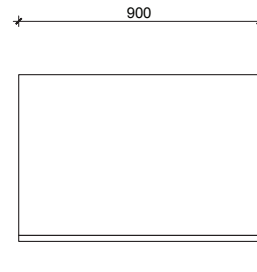
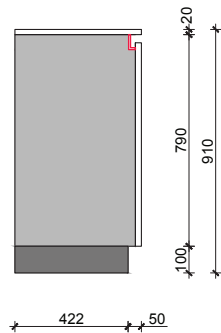
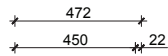
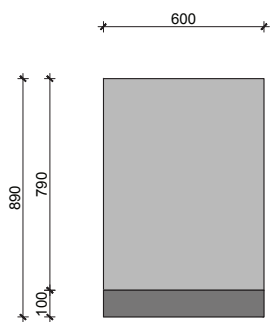
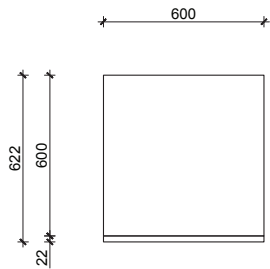
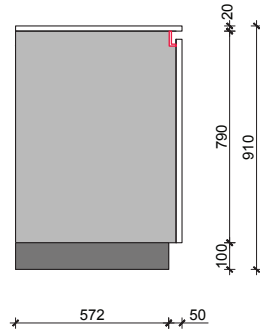
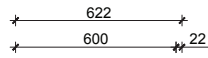
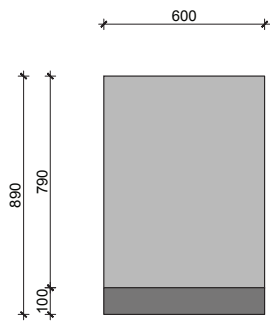
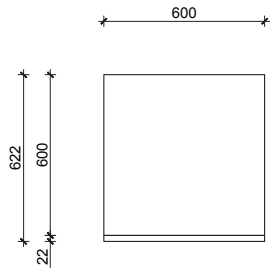

# PROGRAMA STANDARD

ELA WALL UNITS 360, 480, 600, 720, 840

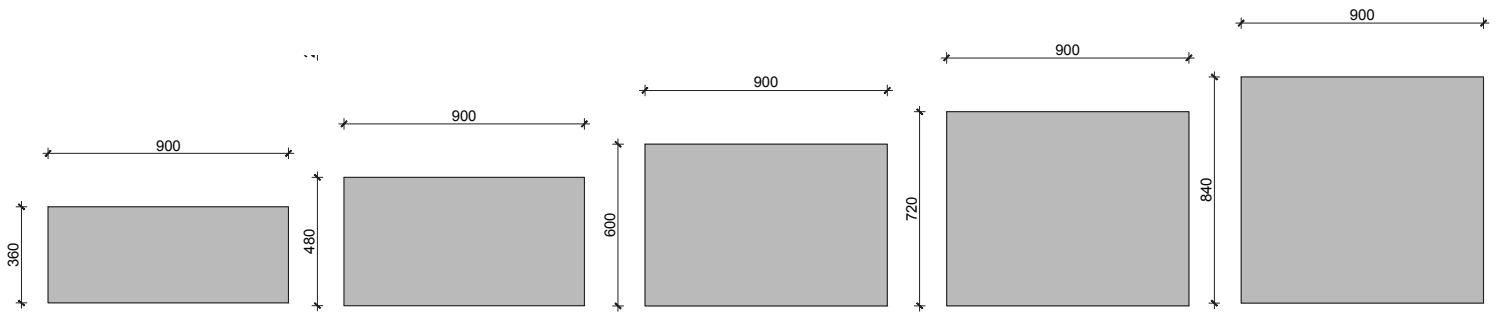
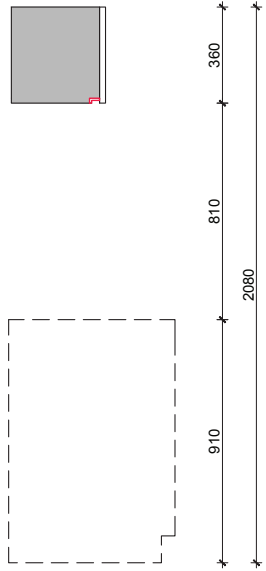
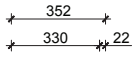



---

# ASTER COLLECTION

---





# CARCASS SIZES

## ASTER STRUCTURAL BASE UNITS

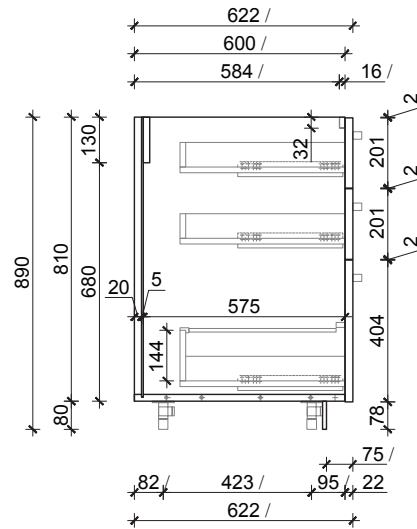
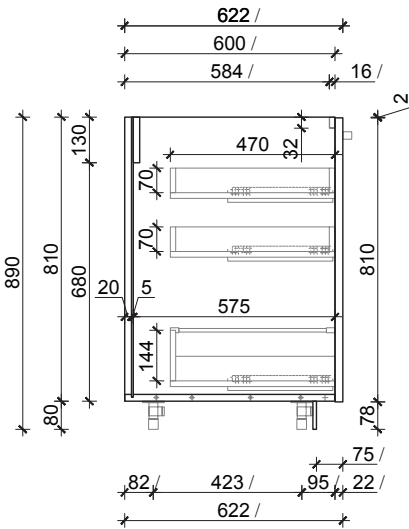
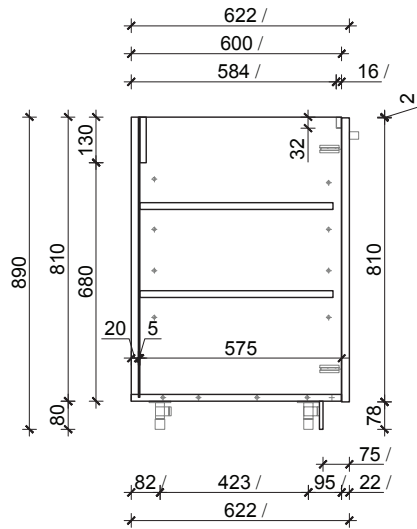
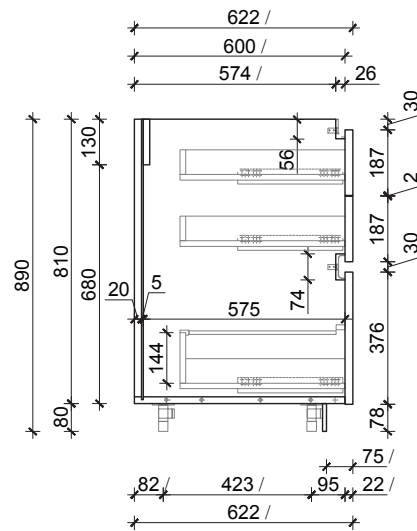
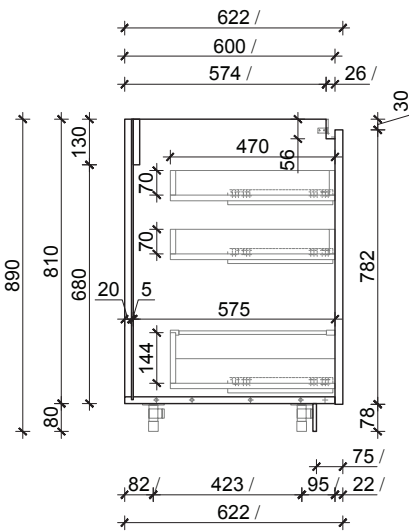
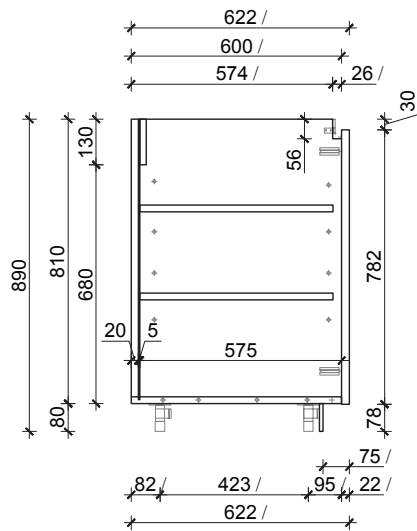



# CARCASS SIZES

## ASTER STRUCTURAL TALL AND WALL UNITS

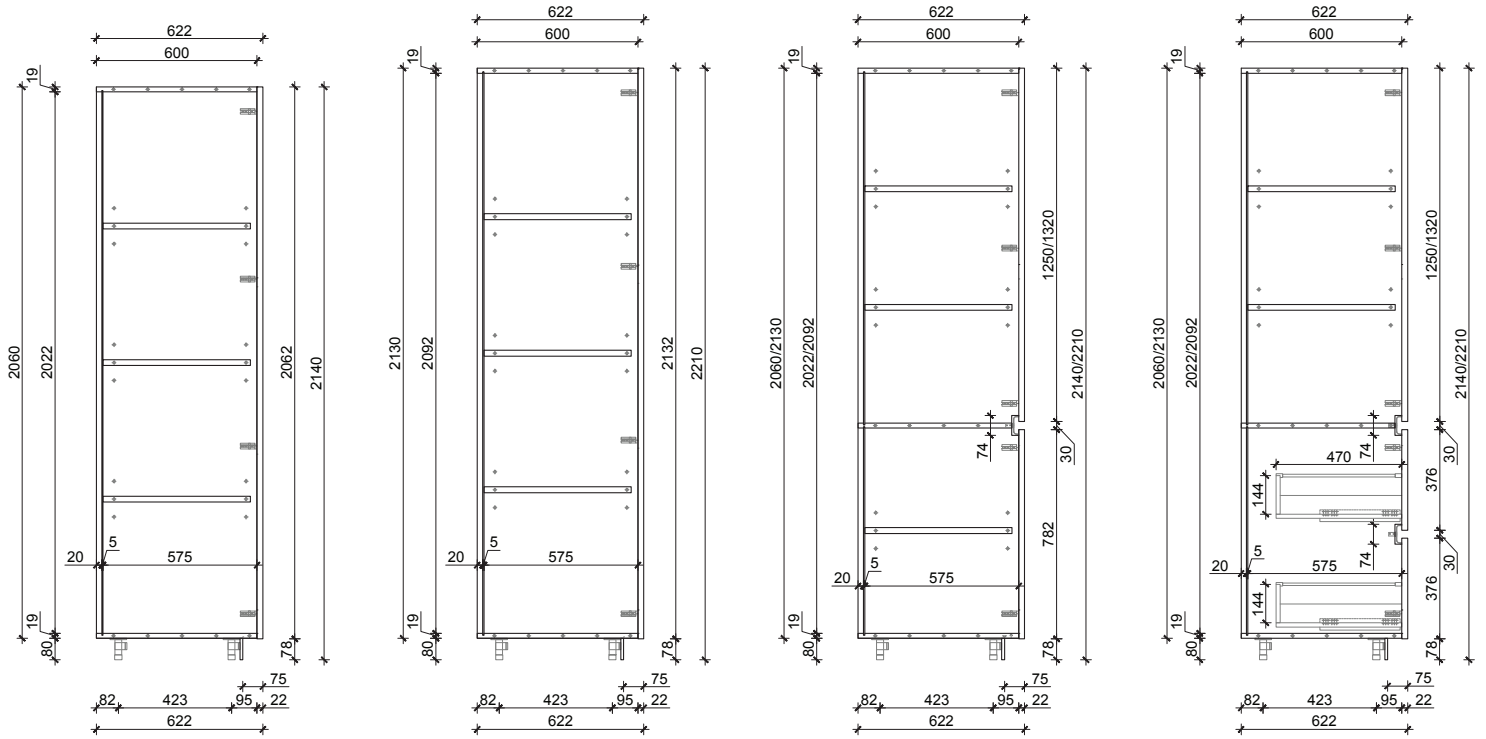

# CARCASS SIZES

## ASTER STRUCTURAL TALL AND WALL UNITS

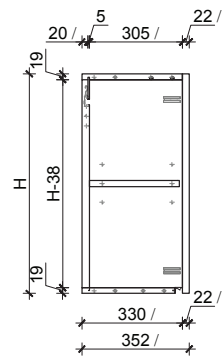
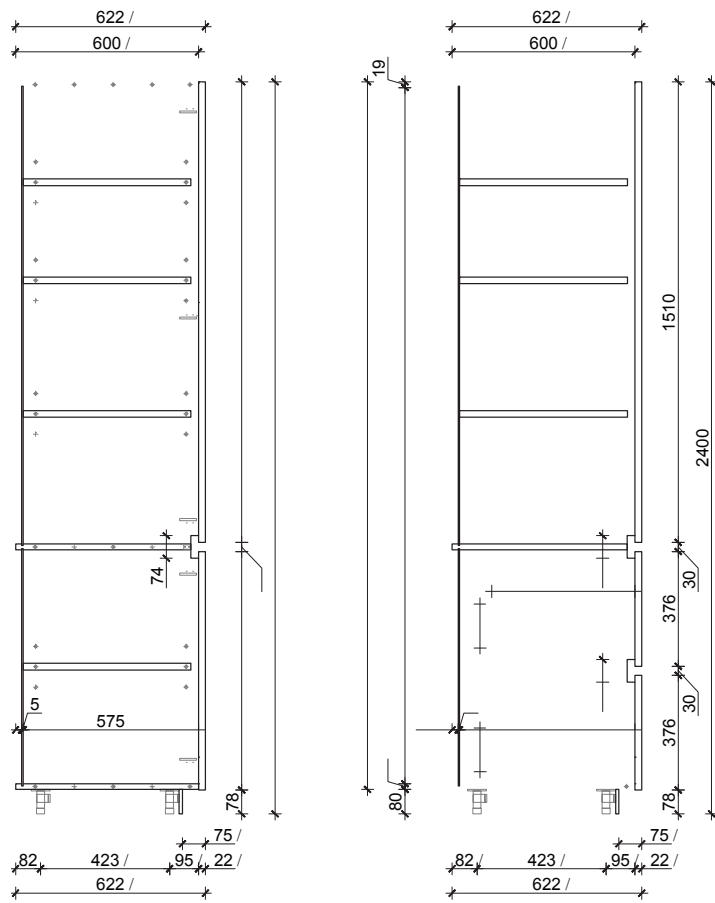

H. cm 44	- no. shelf	0	- 2 hinges
H. cm 60	- no. shelf	1	- 2 hinges
H. cm 72	- no. shelf	1,2	- 2 hinges
H. cm 88	- no. shelf	2	- 2 hinges

# DESIGN PROPOSALS

## ASTER ISLAND CABINETS

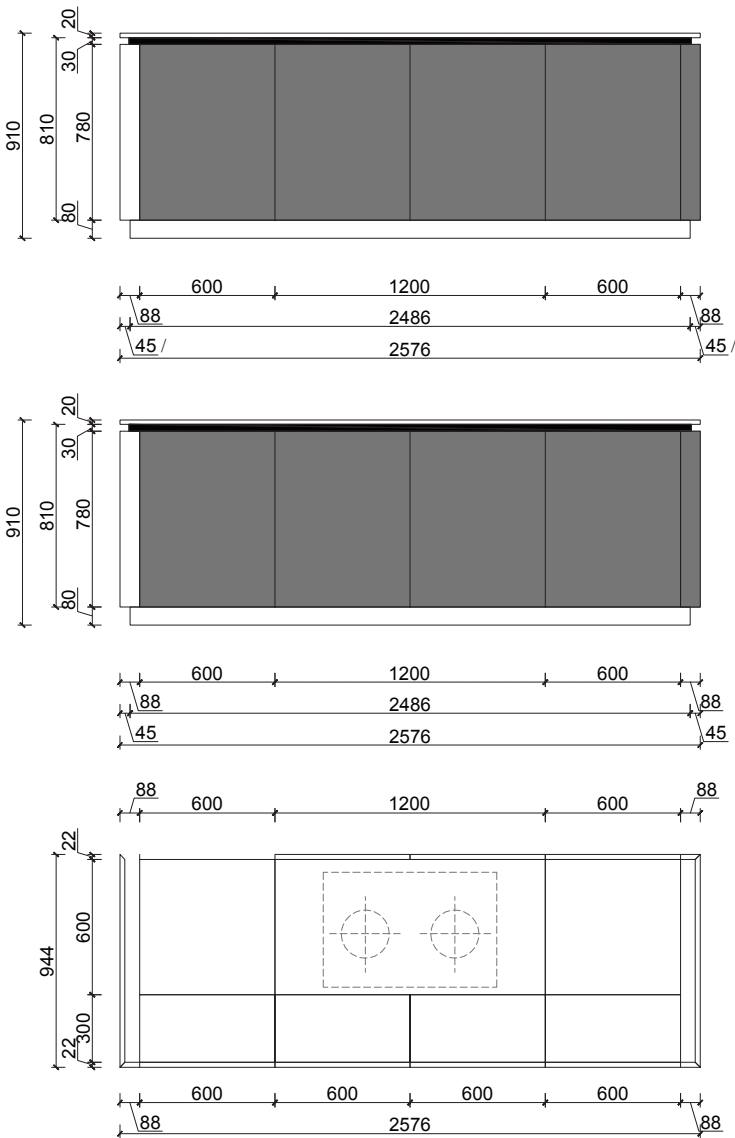

### PROPOSAL 1

1. End side panel  
H= 890 mm, 944 mm deep, 22 mm thick
2. Quartz stone counter  
20 mm thick, W= 2444 mm
3. Aluminum stainless steel spacer  
W= 2400 mm
4. Base unit with shelf  
H= 790 mm, W= 600 mm
5. Base unit with shelf, cook top above  
H= 790 mm, W= 1200 mm
6. Base unit with internal drawers  
H= 790 mm, W= 600 mm
7. Aluminum toe kick  
100 mm high, W= 2400 mm
8. End back panel  
H= 790 mm, W= 600 mm, 22 mm thick.

# DESIGN PROPOSALS

## ASTER ISLAND CABINETS

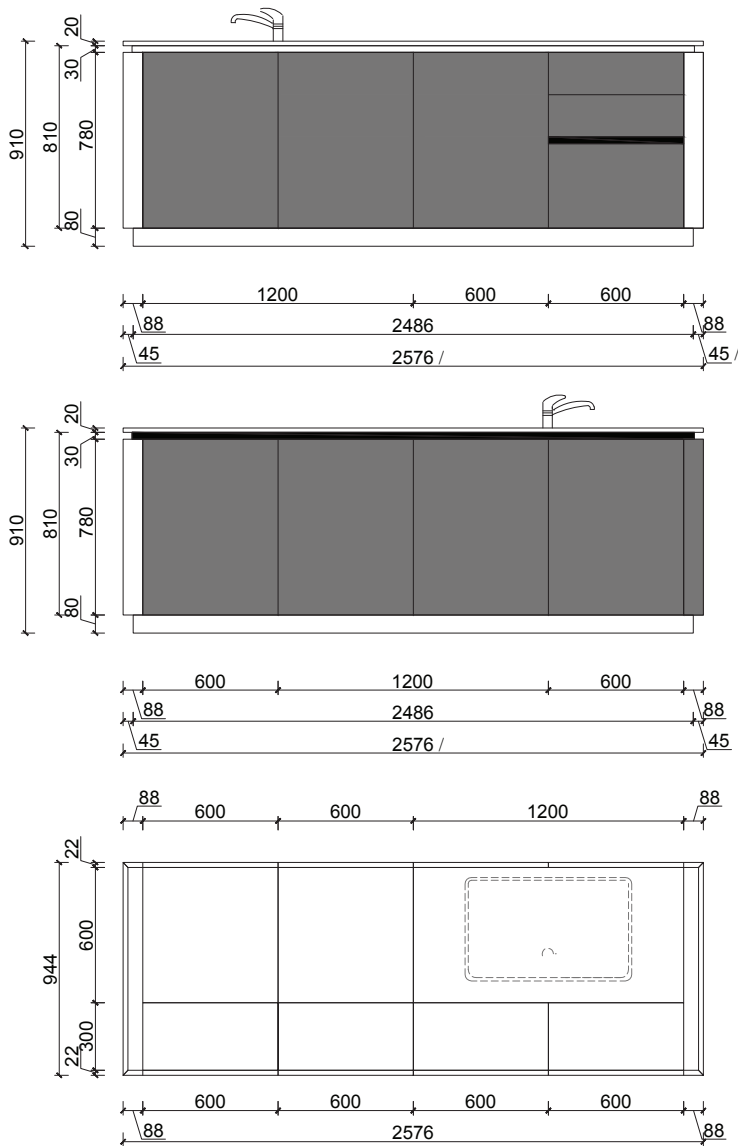

### PROPOSAL 2

1. End side panel  
H= 890 mm, 1094 mm deep, 22 mm thick
2. Quartz stone counter  
20 mm thick, W= 2444 mm
3. Aluminum stainless steel spacer  
W= 2400/1200 mm
4. Aluminum stainless steel spacer  
W= 1200 mm, central use
5. Base unit for sink with drawers  
H= 790 mm, W= 1200 mm
6. Base unit for built-in dish washer  
H= 790 mm, W= 600 mm
7. Base unit with shelf  
H= 790 mm, W= 600 mm
8. Aluminum toe kick  
100 mm high, W= 2400/1200/450 mm
9. Base unit with shelves  
H= 790 mm, W= 600 mm
10. Base unit with shelves  
H= 790 mm, W= 600 mm
11. End back panel  
H= 790 mm, W= 600 mm, 22 mm thick
12. End side panel  
H= 790 mm, W= 450 mm, 22 mm thick.

# DESIGN PROPOSALS

## ASTER ISLAND CABINETS

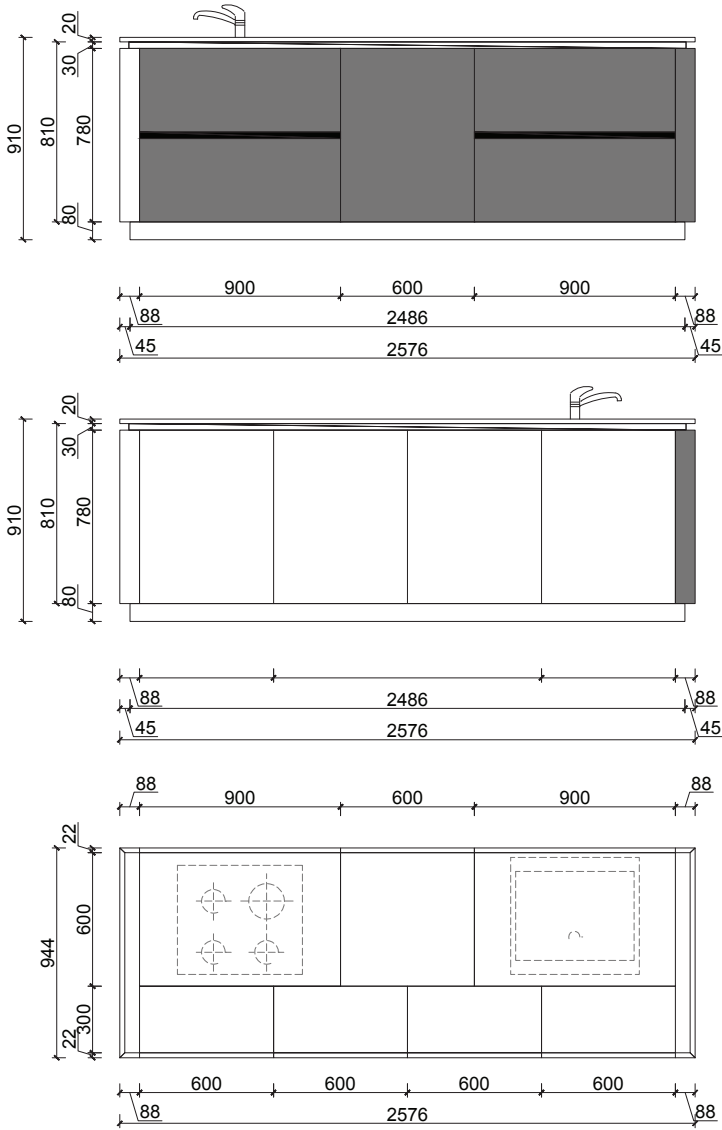

### PROPOSAL 3

1. End side panel  
H= 890 mm, 1094 mm deep, 22 mm thick
2. Quartz stone counter  
20 mm thick, W= 2444 mm
3. Aluminum stainless steel spacer  
W= 2400/1200 mm
4. Aluminum stainless steel spacer  
W= 1800 mm, central use
5. Base unit for built-in dish washer  
H= 790 mm, W= 600 mm
6. Base unit for sink with drawers  
H= 790 mm, W= 900 mm
7. Base unit with drawers, cook top above  
H= 790 mm, W= 900 mm
8. Aluminum toe kick  
100 mm high, W= 2400/1200/450 mm
9. Base unit with shelves  
H= 790 mm, W= 600 mm
10. Base unit with shelves  
H= 790 mm, W= 600 mm
11. End back panel  
H= 790 mm, W= 600 mm, 22 mm thick
12. End side panel  
H= 790 mm, W= 450 mm, 22 mm thick.

# DESIGN PROPOSALS

## ASTER ISLAND CABINETS

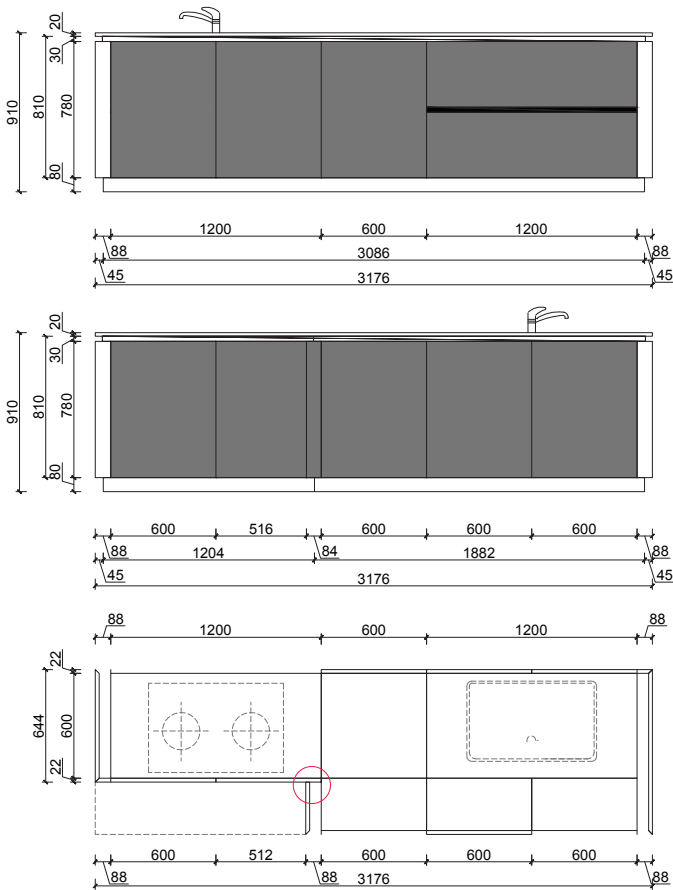

### PROPOSAL 4

1. End side panel  
H= 890 mm, 1094 mm deep, 22 mm thick
2. Quartz stone counter  
20 mm thick, W= 2444 mm
3. Aluminum stainless steel spacer  
W= 2400/1200 mm
4. Aluminum stainless steel spacer  
W= 1200 mm, central use
5. Base unit for sink  
H= 790 mm, W= 1200 mm
6. Base unit for built-in dish washer, cook top above  
H= 790 mm, W= 600 mm
7. Base unit with internal drawers, cook top above  
H= 790 mm, W= 600 mm
8. Aluminum toe kick  
100 mm high, W= 2400/1200/450 mm
9. Base unit with shelves  
H= 790 mm, W= 600 mm
10. Base unit with shelves  
H= 790 mm, W= 600 mm
11. End back panel  
H= 790 mm, W= 600 mm, 22 mm thick
12. End side panel  
H= 790 mm, W= 450 mm, 22 mm thick.

# DESIGN PROPOSALS

## ELA TALL CABINETS

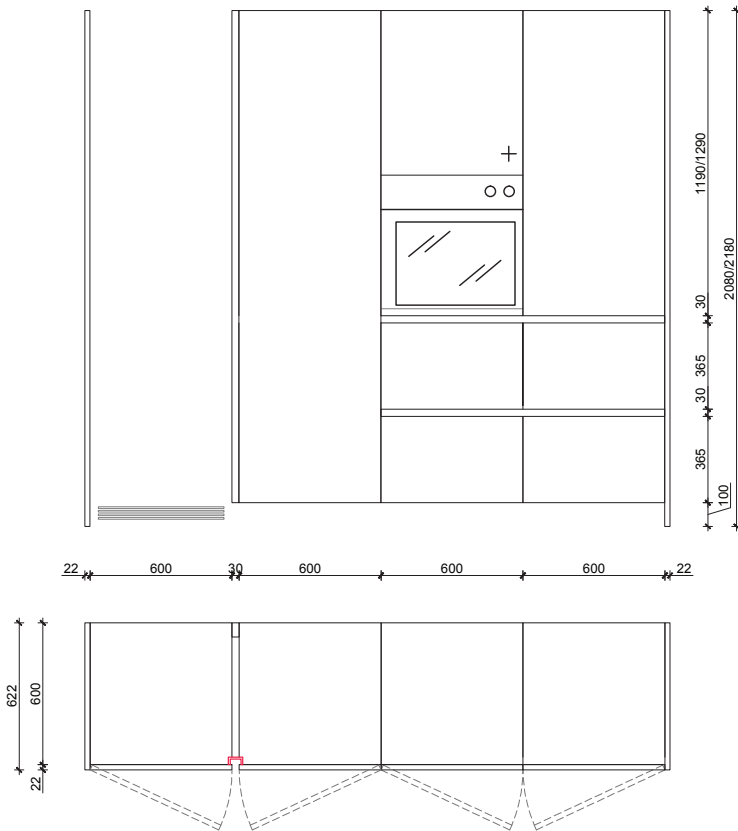

### PROPOSAL 5

1. End side panel  
H= 2080/2180 mm, 622 mm deep, 22 mm thick
2. Tall unit for refrigerator  
H= 1980/2080 mm, W= 600 mm
3. Aluminum stainless steel spacer, central use  
H= 1980/2080 mm
4. Tall unit - tandem pantry  
H= 1980/2080 mm, W= 600 mm
5. Tall unit with for oven with drawers  
H= 1980/2080 mm, W= 600 mm
6. Tall unit with shelves and drawers  
H= 1980/2080 mm, W= 600 mm
7. Aluminum stainless steel spacer,  
W= 600 mm
8. Aluminum stainless steel spacer, central use  
W= 600/1200
9. Aluminum toe kick  
100 mm high, W= 2430 mm.

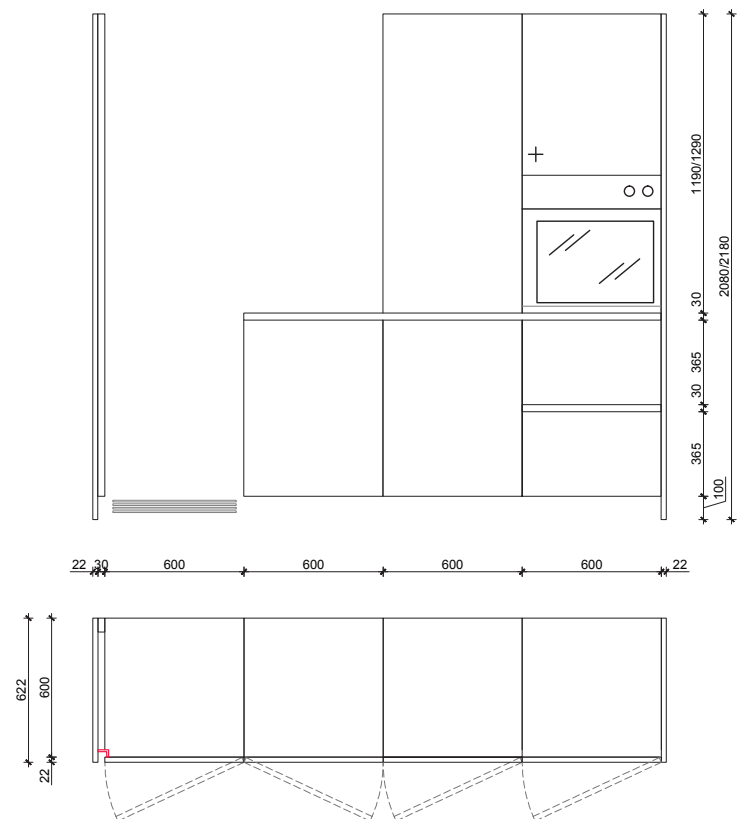

### PROPOSAL 6

1. End side panel  
H= 2080/2180 mm, 622 mm deep, 22 mm thick
2. Aluminum stainless steel spacer  
H= 1980/2080 mm
3. Tall unit for refrigerator  
H= 1980/2080 mm, W= 600 mm
4. Tall unit with shelves  
H= 1980/2080 mm, W= 600 mm
5. Tall unit with shelves  
H= 1980/2080 mm, W= 600 mm
6. Tall unit for oven with drawers,  
H= 1980/2080 mm, W= 600 mm
7. Aluminum stainless steel spacer, central use  
W= 600/1200 mm
8. Aluminum stainless steel spacer  
W= 600 mm
9. Aluminum toe kick  
100 mm high, W= 2430 mm

# DESIGN PROPOSALS

## ASTER TALL UNITS

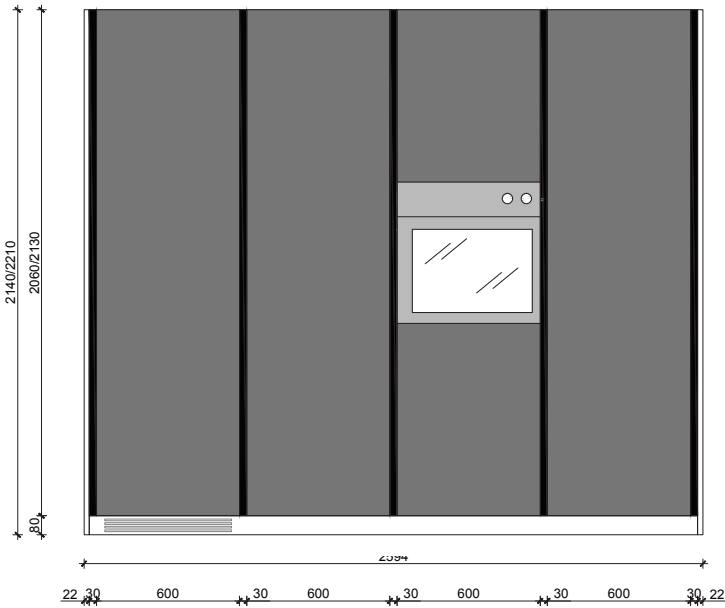

### PROPOSAL 1

1. End side panel  
H= 2140/2210 mm, 622 mm deep, 22 mm thick
2. Aluminum stainless steel spacer  
H= 2060/2130 mm
3. Tall unit for refrigerator  
H= 2060/2130 mm, W= 600 mm
4. Aluminum stainless steel spacer, central use  
H= 2060/2130 mm
5. Tall unit with shelves  
H= 2060/2130 mm, W= 600 mm
6. Tall unit for oven with shelves  
H= 2060/2130 mm, W= 600 mm
7. Tall unit - tandem pantry  
H= 2060/2130 mm, W= 600 mm
8. Aluminum toe kick  
80 mm high, W= 2550 mm.

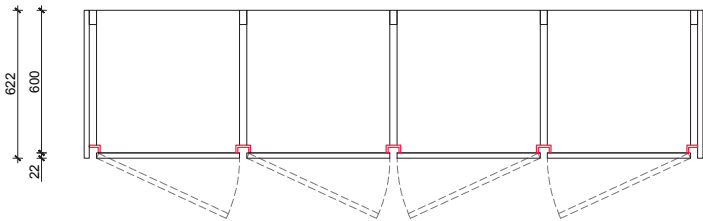

### PROPOSAL 2

1. End side panel  
H= 2140/2210 mm, 622 mm deep, 22 mm thick
2. Aluminum stainless steel spacer  
H= 2060/2130 mm
3. Tall unit with - tandem pantry  
H= 2060/2130 mm, W= 600 mm
4. Aluminum stainless steel spacer, central use  
H= 2060/2130 mm
5. Tall unit - tandem pantry  
H= 2060/2130 mm, W= 600 mm
6. Tall unit for oven with shelves  
H= 2060/2130 mm, W= 600 mm
7. Tall unit for refrigerator  
H= 2060/2130 mm, W= 600 mm
8. Aluminum toe kick  
80 mm high, W= 2550 mm.

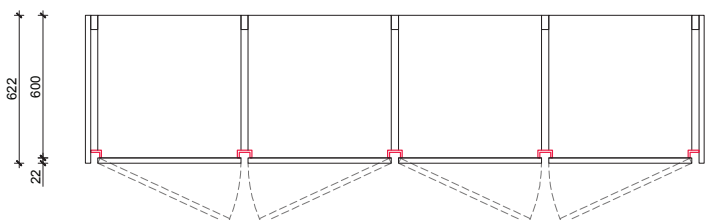
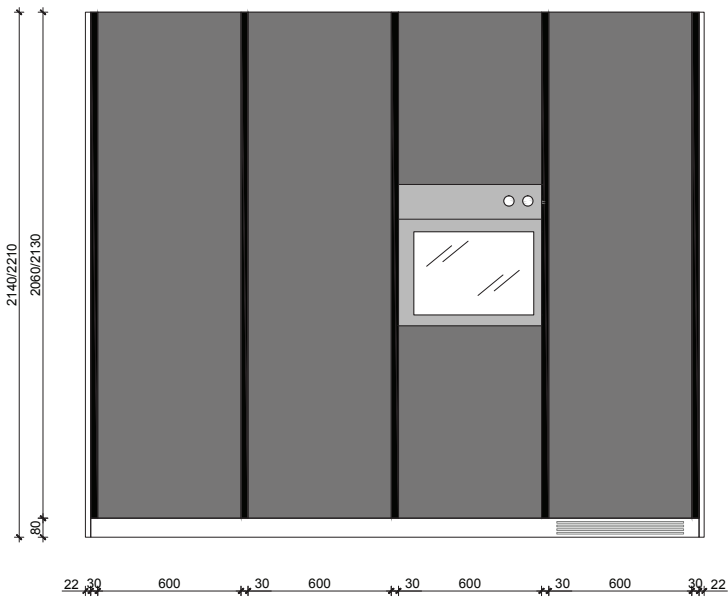



# DESIGN PROPOSALS

## ASTER TALL UNITS

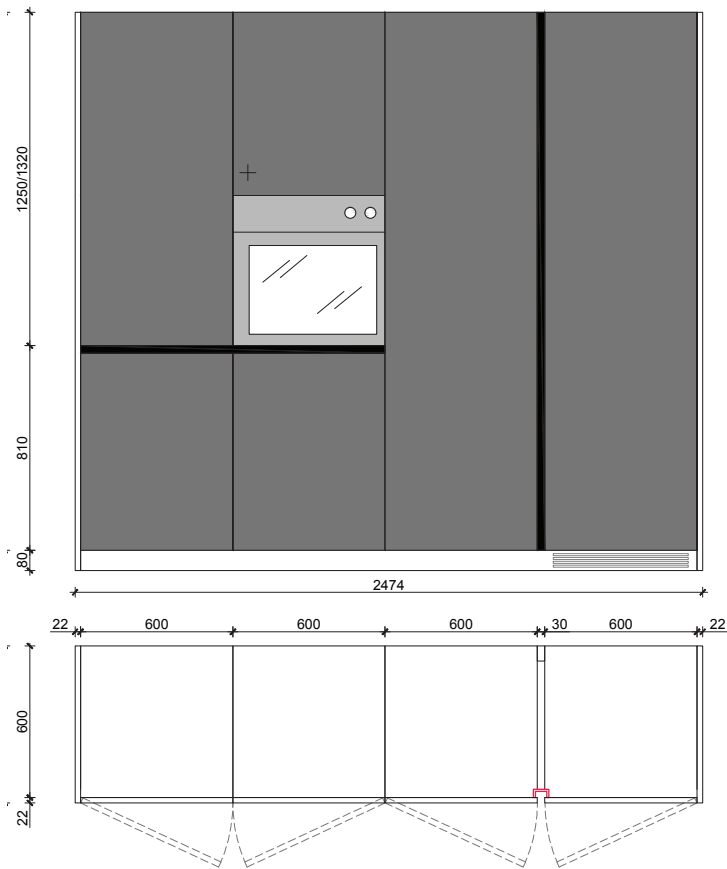

### PROPOSAL 3

1. End side panel  
H= 2140/2210 mm, 622 mm deep, 22 mm thick
2. Tall unit with shelves and internal drawers  
H= 2060/2130 mm, W= 600 mm
3. Tall unit for oven with internal drawers  
H= 2060/2130 mm, W= 600 mm
4. Tall unit - tandem pantry  
H= 2060/2130 mm, W= 600 mm
5. Aluminum stainless spacer, central use  
H= 2060/2130 mm
6. Tall unit for refrigerator  
H= 2060/2130 mm, W= 600 mm
7. Aluminum stainless steel spacer, central use  
W= 600 mm
8. Aluminum stainless steel spacer  
W= 600 mm
9. Aluminum toe kick  
80 mm high, W= 2430 mm

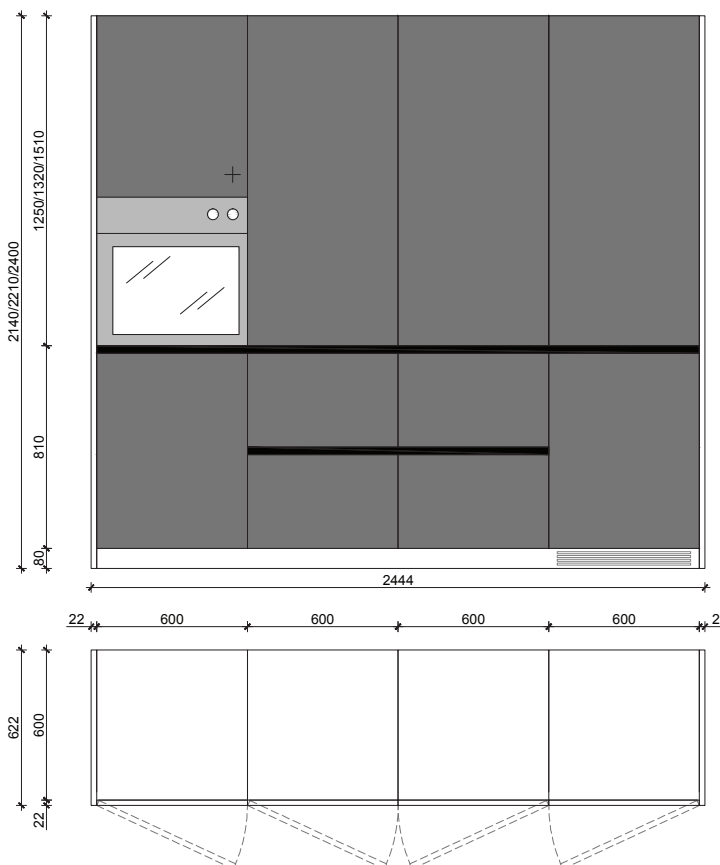

### PROPOSAL 4

1. End side panel  
H= 2140/2210 mm, 622 mm deep, 22 mm thick
2. Tall unit for oven with shelves  
H= 2060/2130 mm, W= 600 mm
3. Tall unit with shelves and drawers  
H= 2060/2130 mm, W= 600 mm
4. Tall unit with shelves and drawers  
H= 2060/2130 mm, W= 600 mm
5. Tall unit with shelves  
H= 2060/2130 mm, W= 600 mm
6. Aluminum stainless steel spacer  
W= 600 mm
7. Aluminum stainless steel spacer, central use  
W= 1800/1200 mm
8. Aluminum toe kick  
80 mm high, W= 2400 mm.

# PROGRAMA STANDARD

## ASTER BASE CABINETS

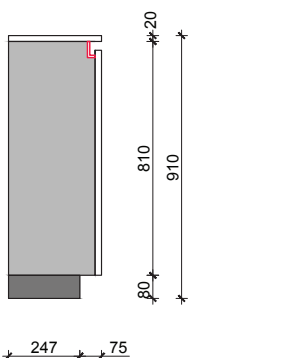
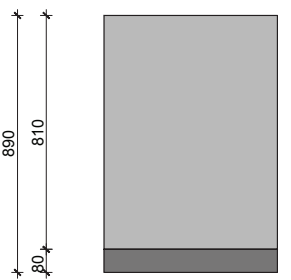
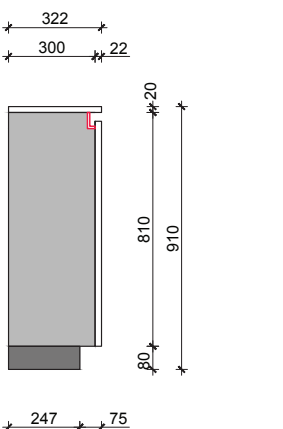
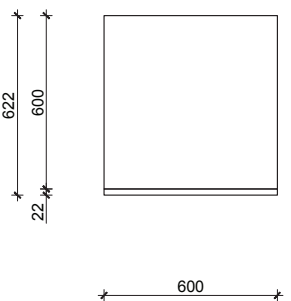
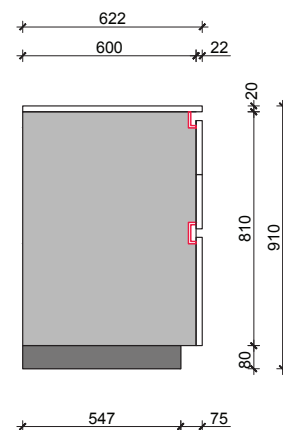
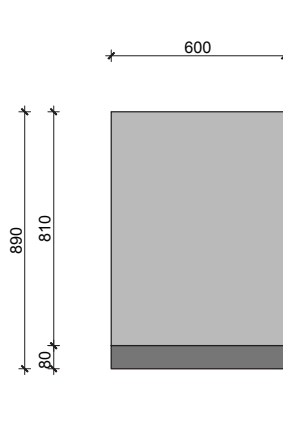
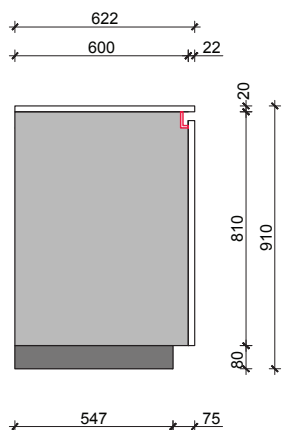
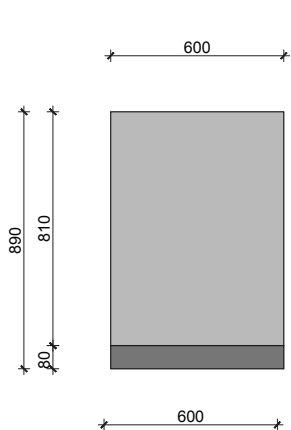
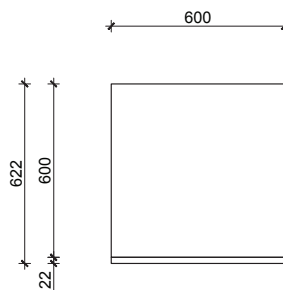
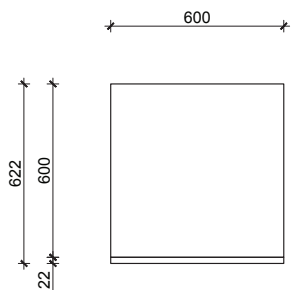

# PROGRAMA STANDARD

## ASTER TALL UNITS

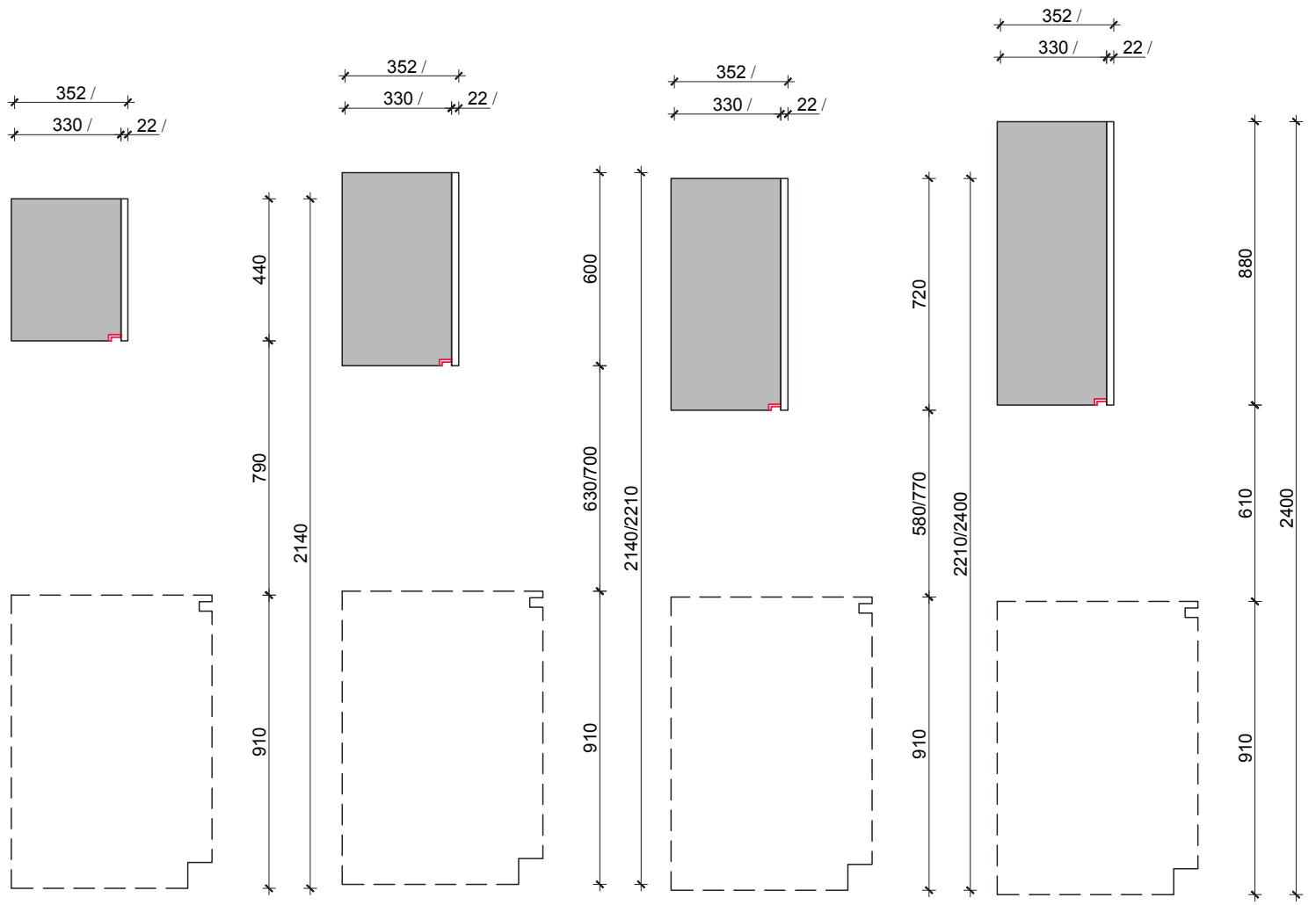

# PROGRAMA STANDARD

## ASTER TALL UNITS

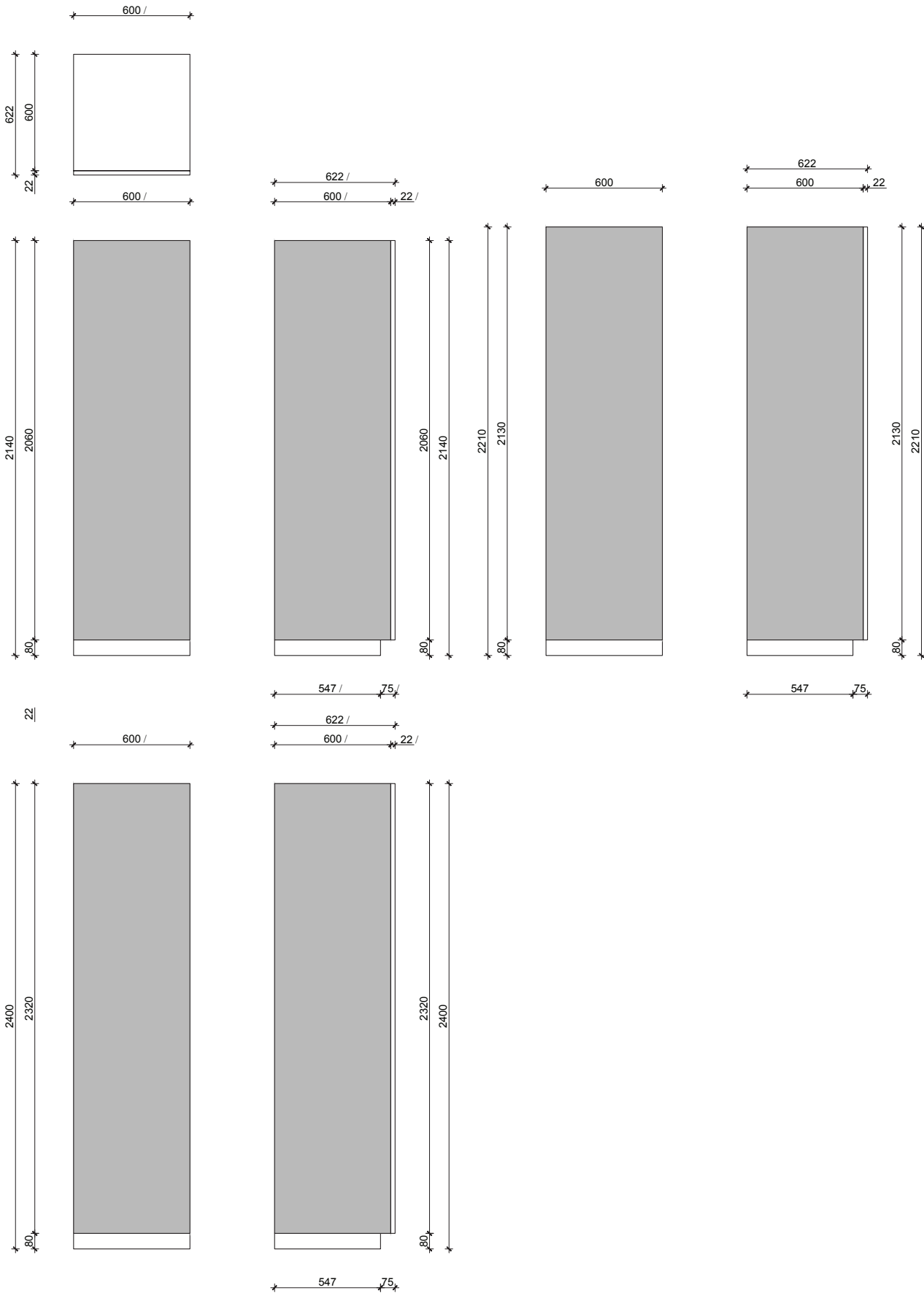

---

# PROGRAMA STANDARD

---

## ASTER TALL UNITS

---

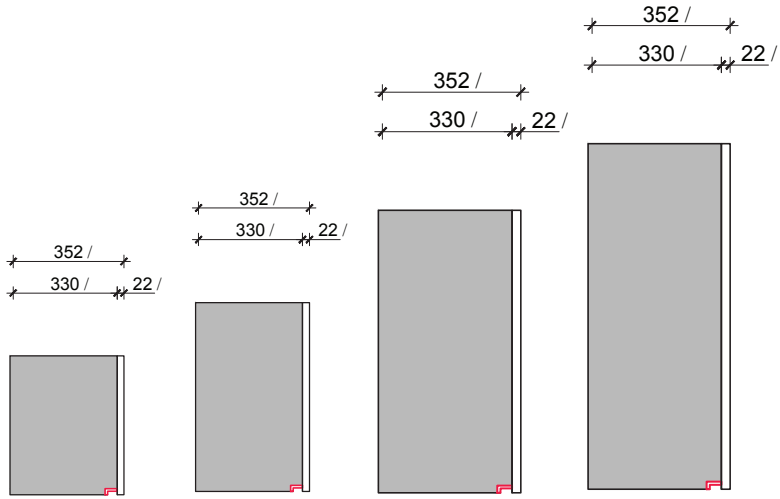

# FIORE

## CUCINE

---

©Copyright FiORE™

NORTH AMERICA  
315 Place d'Youville  
Ste.268  
Montreal, QC H2Y 2B5

EUROPE  
GRUPPO FIORE  
via Stazione 4  
28053 Castelletto Sopra Ticino, NO  
Italia

USA  
FIORE NORTH AMERICA - USA  
311 North Roberston Blvd. Ste. 920  
Los Angeles, CA 90211  
U.S.A

### EMAIL

For an expedited response please email us at  
[support@fiorelife.com](mailto:support@fiorelife.com)

Edition 2017

The data and facts expressed herein are current as of August 7 2017. FiORE reserves the right to implement technical modifications at any time, and without prior notice.